

X-ray area detectors with temporal resolution in the pico-second range

Andreas Oelsner, Surface Concept GmbH Mainz

Impacts from time-resolving photoemission electron microscopy:

Surface Concept GmbH was founded 2005 and since develops complete position sensitive pico-second detection systems (2010: 5 permanent employees, 4 temporary)

Fields of activities:

Imaging Microchannel-Plate Detectors and Spectroscopy Detectors with high temporal resolution

Particle Optics, Spin Detection

Technology Services

delay line detector – principle of operation

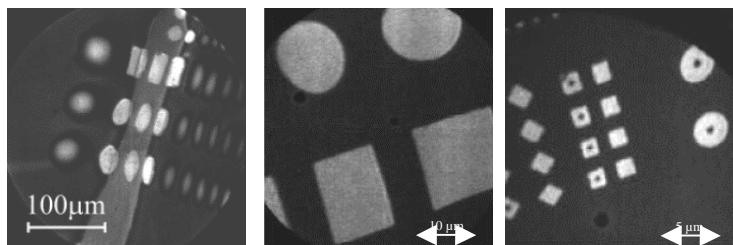
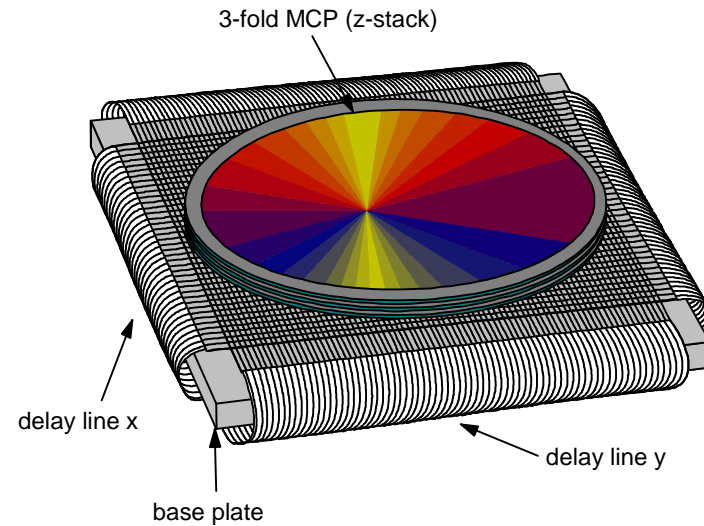
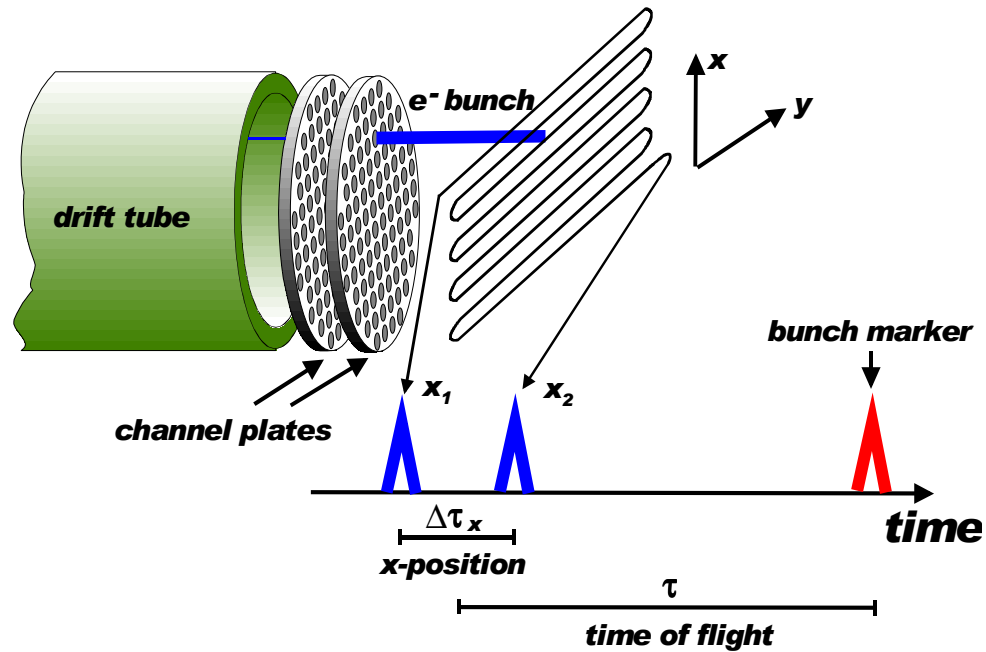

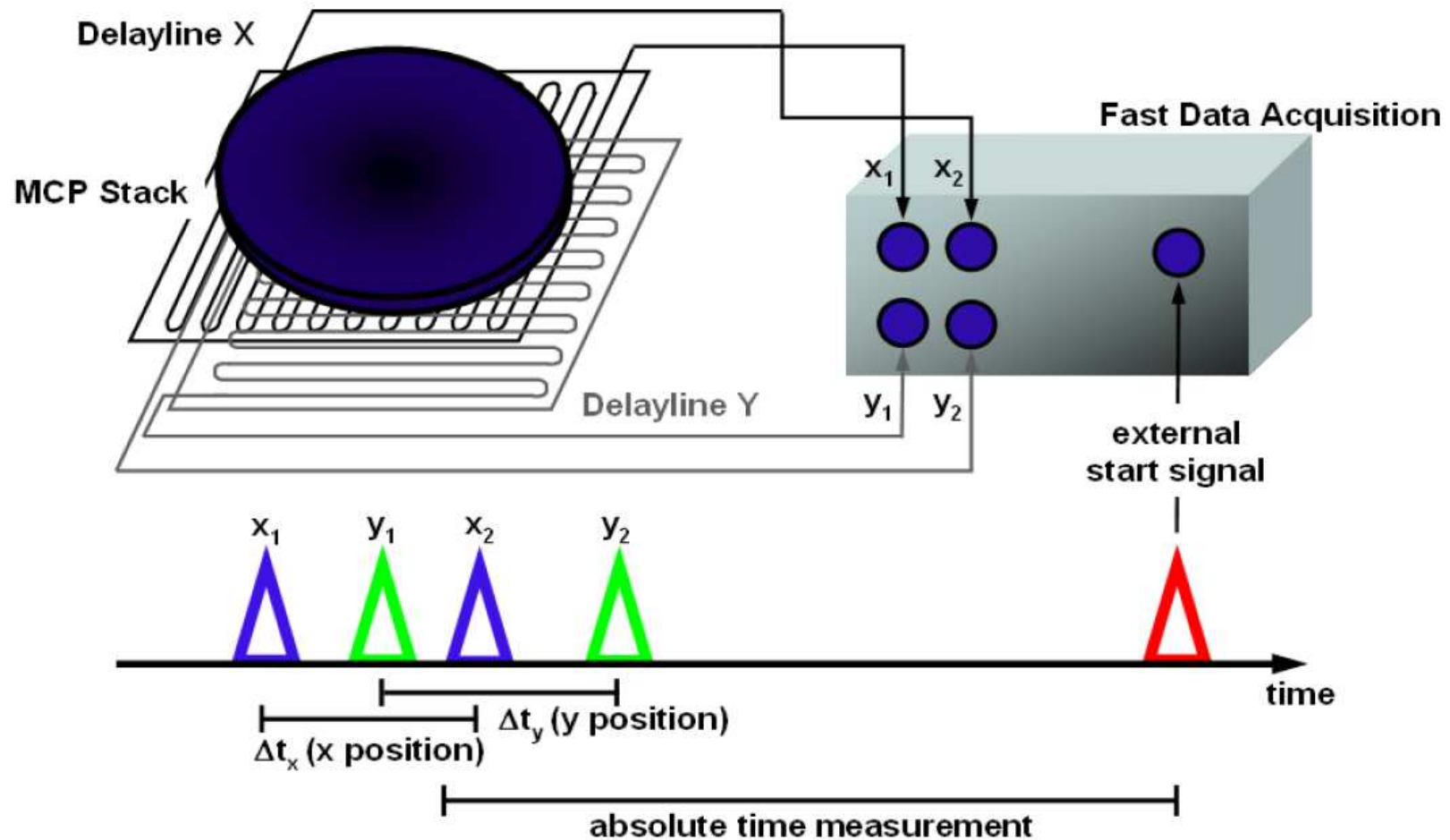

Observation of a workfunction contrast change crossing the photoemission threshold edge from a Ni-Fe frame ($25\mu\text{m}$ size) at a copper surface. It was measured using a 1kHz pulsed femtosecond VUV laser source ($h\nu = 27\text{eV}$) for excitation. Each time slice of 133 ps corresponds to a kinetic energy window of 0.15 eV given by the used settings of the ToF instrument (drift energy of 50 eV).

The same time resolution would enable an energy resolution of 0.014 eV @ 10 eV drift energy, that was already proven for high quality imaging with the same instrument.

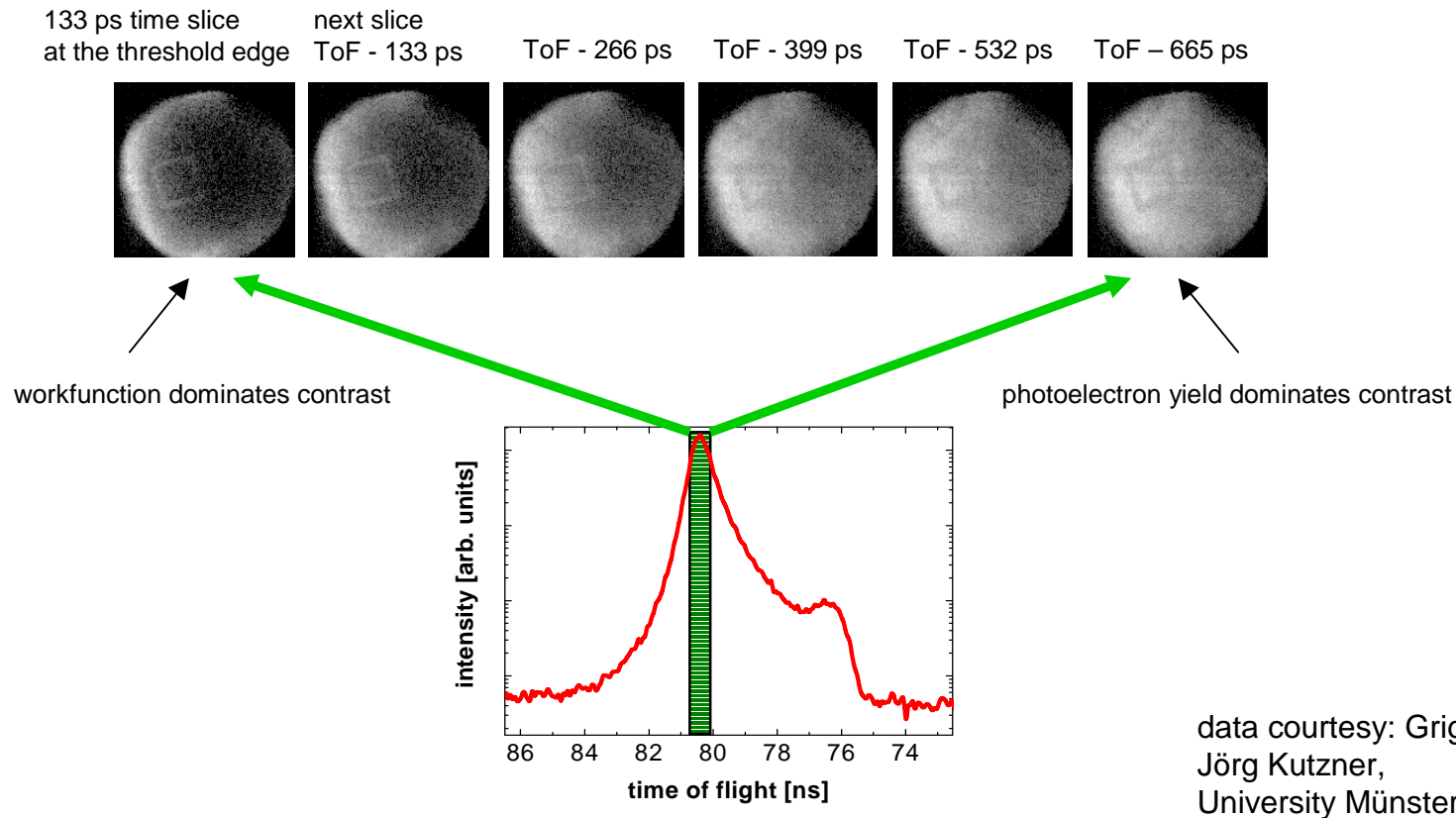

(Nuclear physics: Spark chambers and gas proportional counters:

G. Charpak et al., Nucl. Instrum. Methods 65, 217 (1968))

Orange type beta spectrometer GSI Darmstadt

H. Keller, G. Klingelhöfer, and E. Kankeleit.

[A position sensitive microchannelplate detector using a delay line readout anode.](#)

Nucl. Instrum. Methods A, 258, 221-224 (1987).

X-ray/UV astronomy, Space Science Lab Berkeley, GALEX, COS, FUSE missions,

M. Lampton, O. Siegmund, and R. Raffanti.

[Delay line anodes for microchannel-plate spectrometers.](#)

Rev. Sci. Instrum., 12, 2298-2305 (1987).

Delayline detectors are true counting, imaging detectors with time resolution:

- time slice images can be taken with time windowing down to below 100 ps
- true single counting system, thus high linearity in hit rate response
- very high sensitivity
- brilliant signal / background ratio

Applications:

- gated imaging and spectroscopy tasks for X-ray and EUV spectroscopy,
- time resolved X-ray and EUV imaging
- true photon counting imaging tasks with large areas up to 120 mm detection size
- time of flight analysis for charged particles

High speed camera systems:

(typ. 1/10000 sec., sequentially sampled frames)

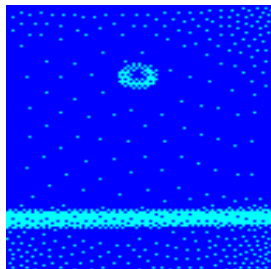

Delayline detectors:

(typ. 1/10000000000 sec., but all single events of all relative times measured simultaneously sampled over many periods)

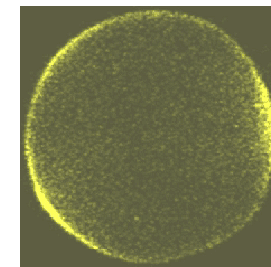

Dead-time of DLD system determined to be below 20 ns

The dead time fits follow the relationship of count rate N_1 to be observed and The true count rate N for an ideal counter with a non-extended dead time τ :

$$N_1 = N / (1 + N \tau)$$

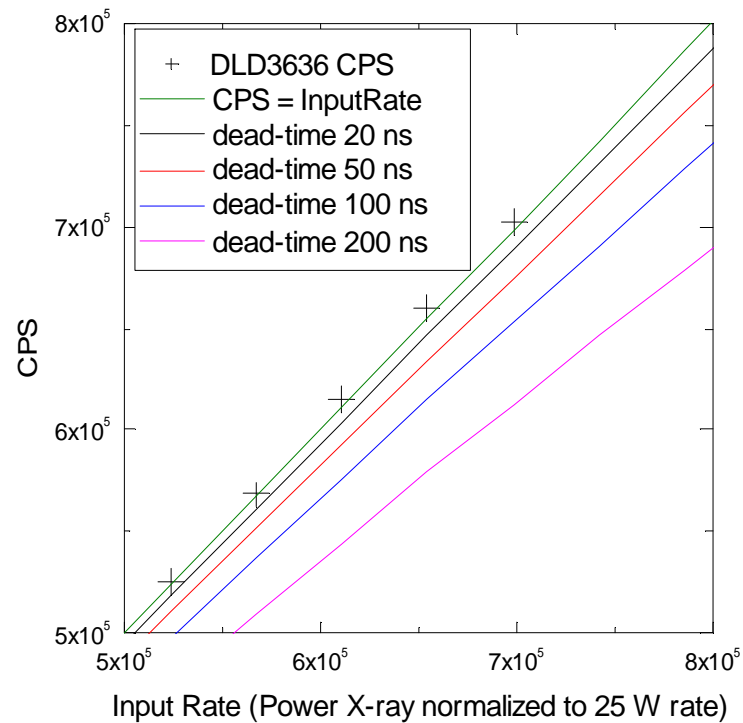
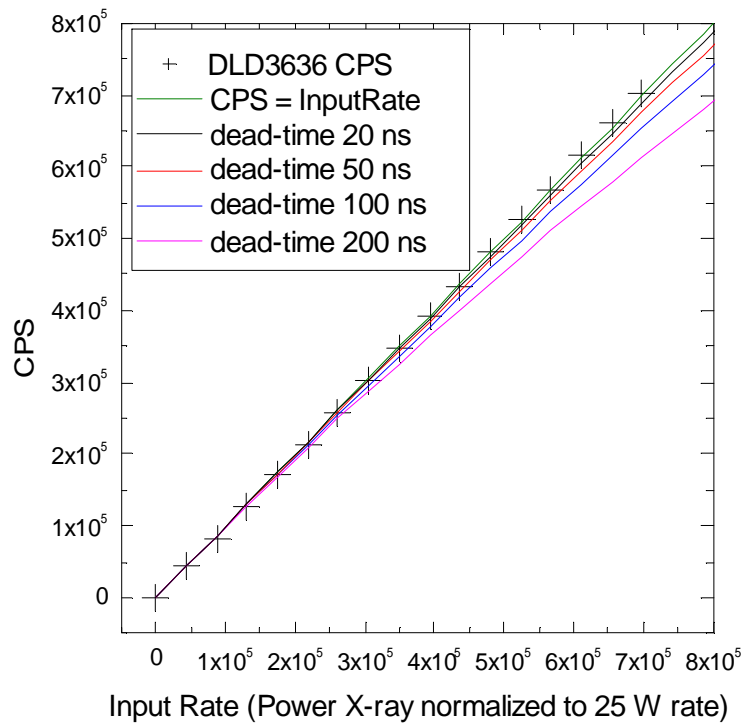

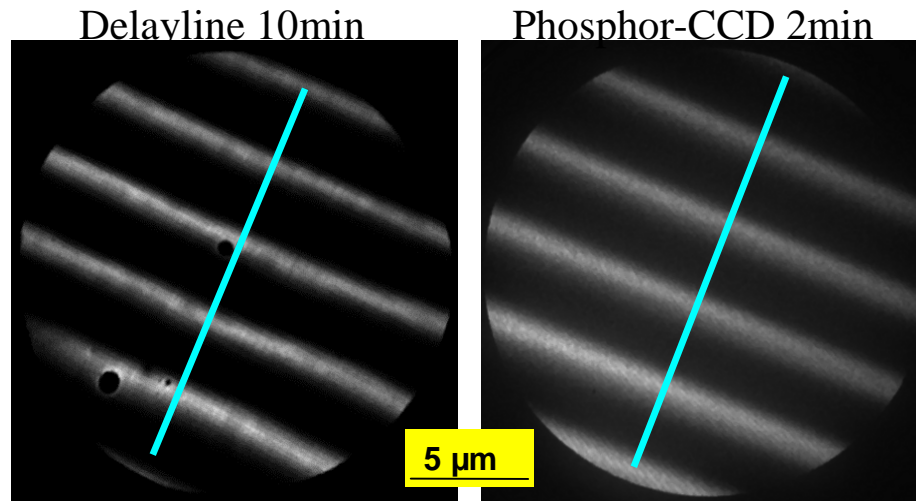

delay line detector – high energy XPS at 3 CPS:

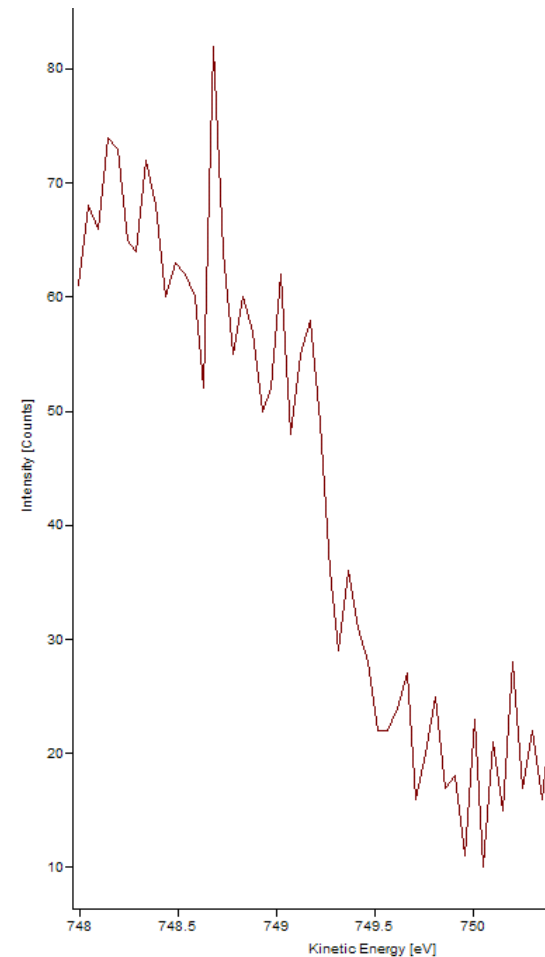
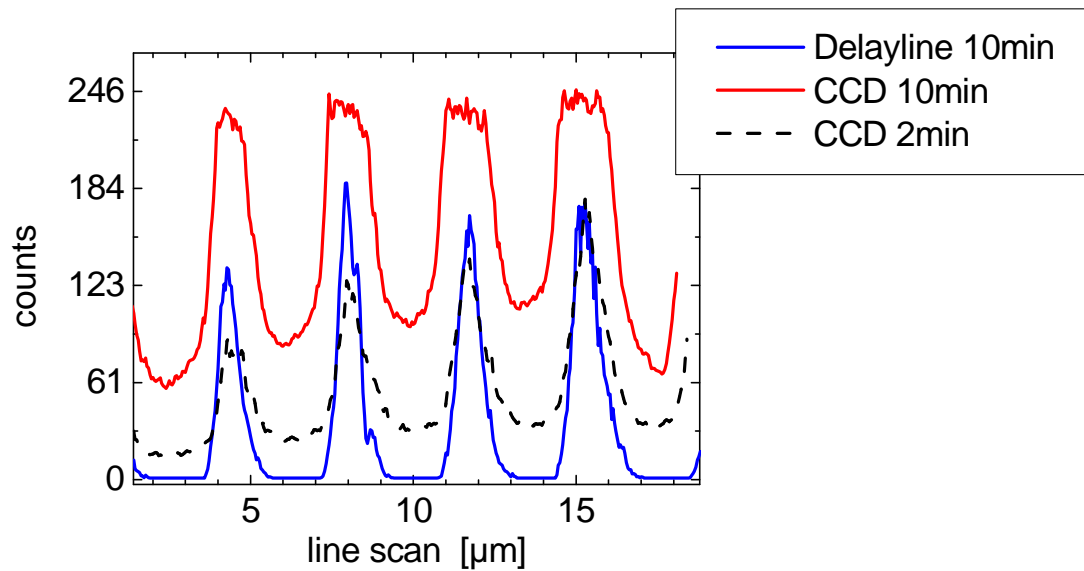

Challenge of 10^6 Signal-Background Ratio?

$>10^7$ counts

36 counts

Need still
factor 3!

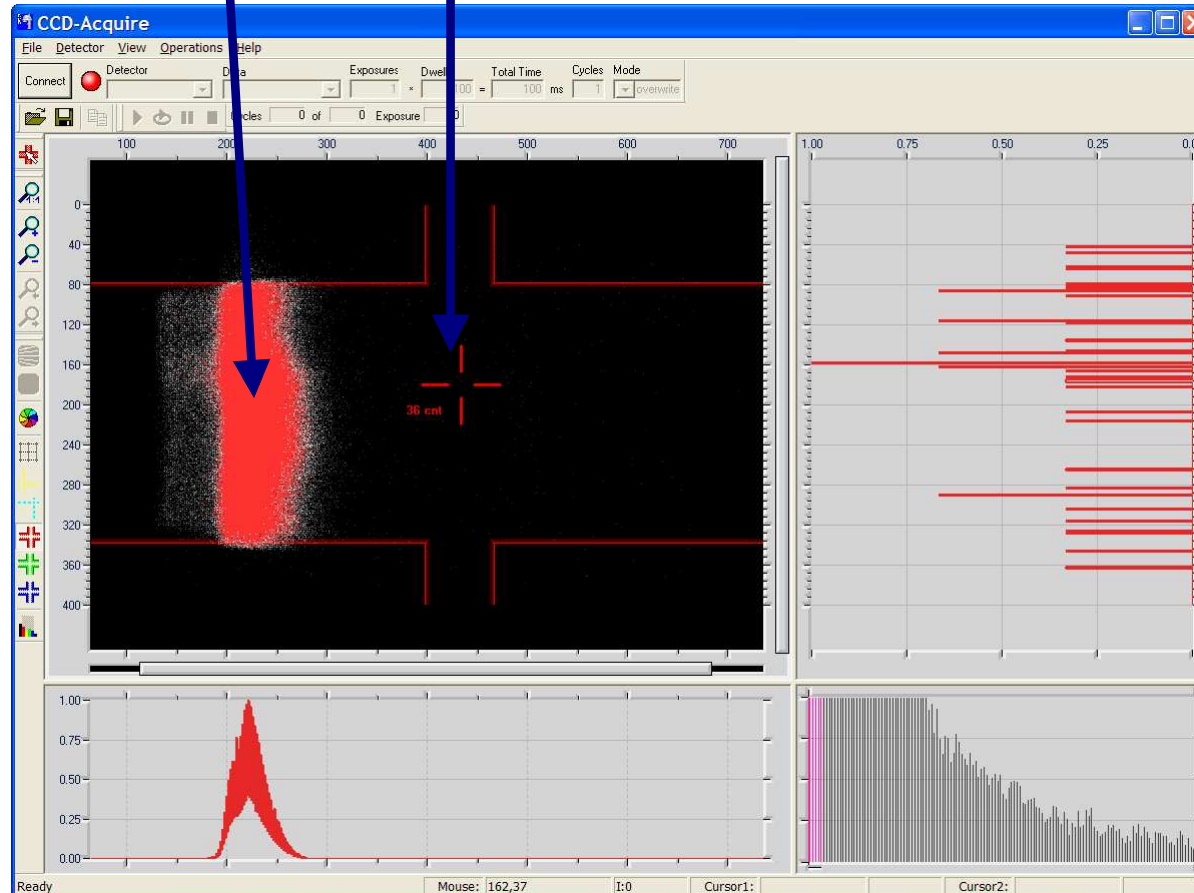

X-ray Delayline Detector

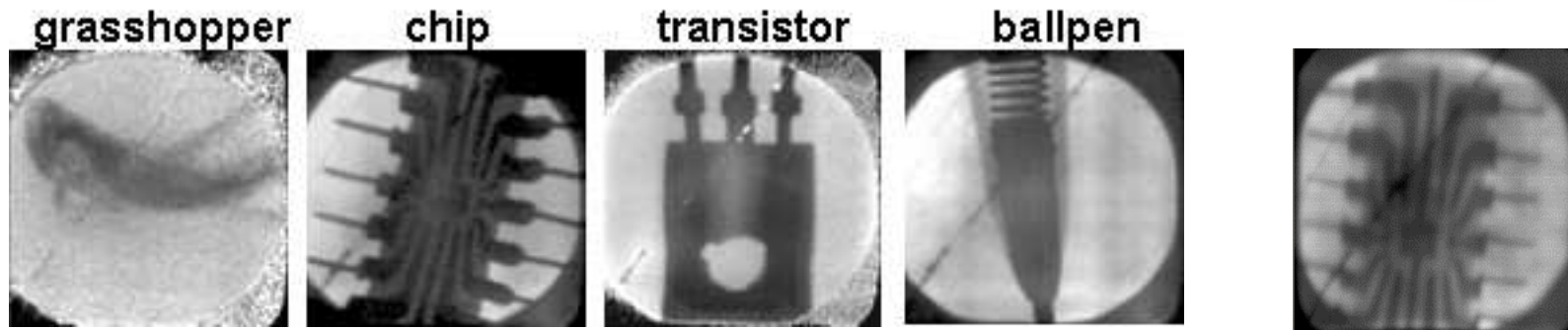
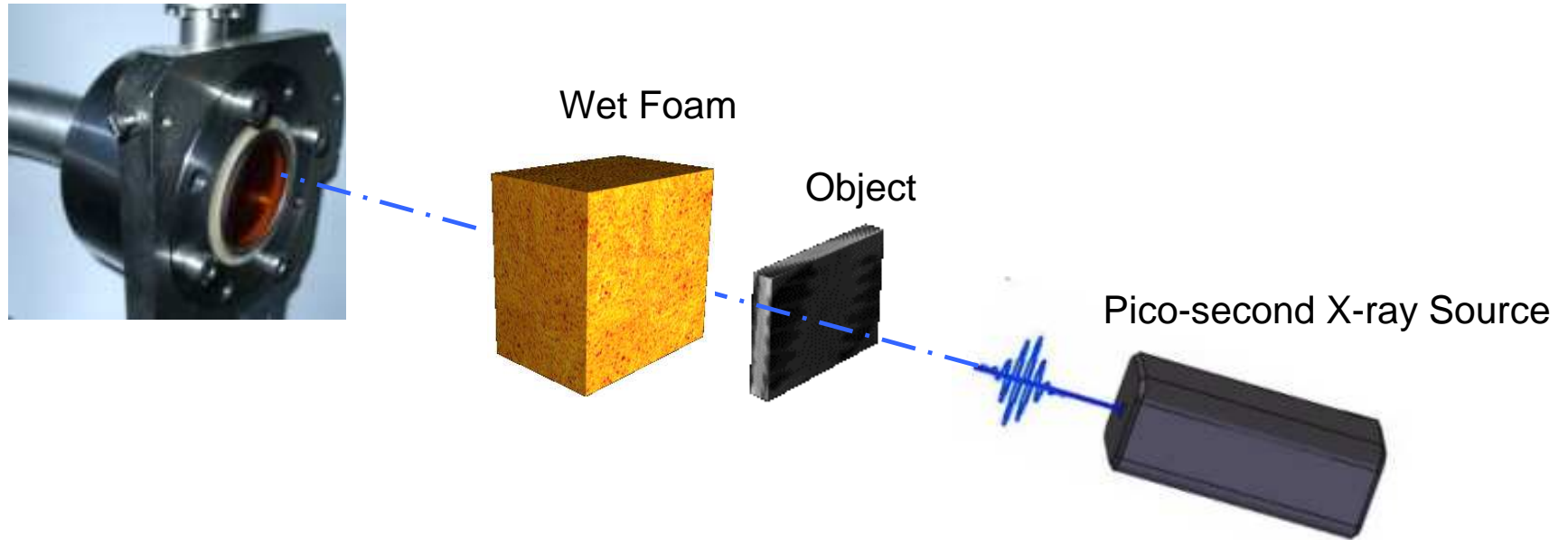

Ulf Hinze, Boris Chichkov, Laserzentrum Hannover, Andreas Oelsner, Surface Concept

125 ps Time Slice All Times Image

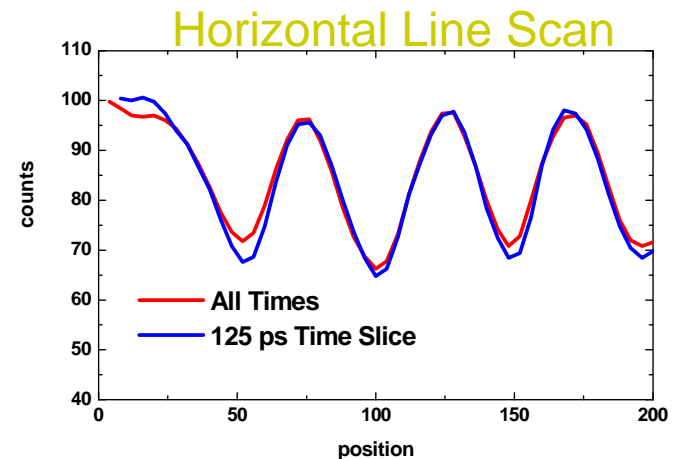
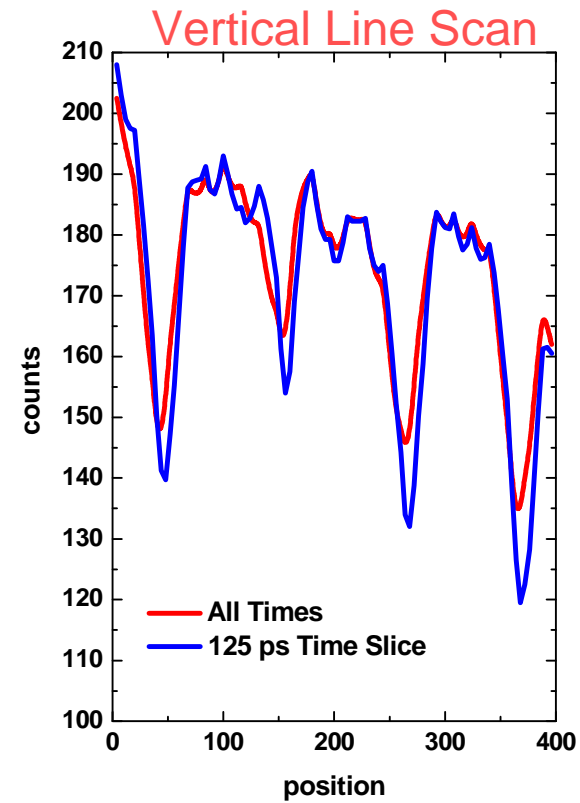
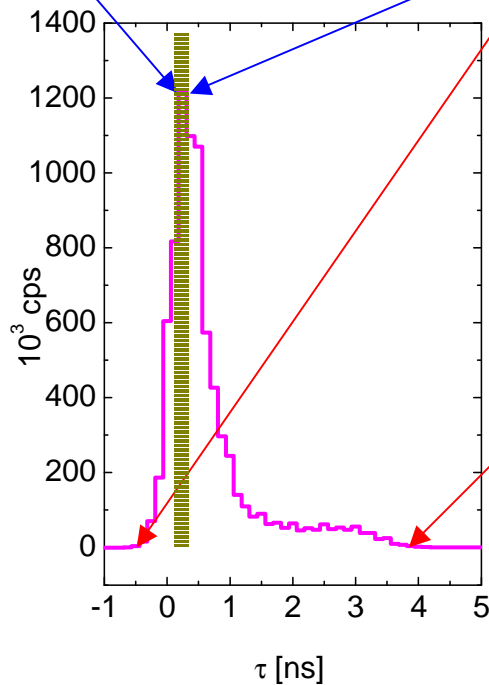
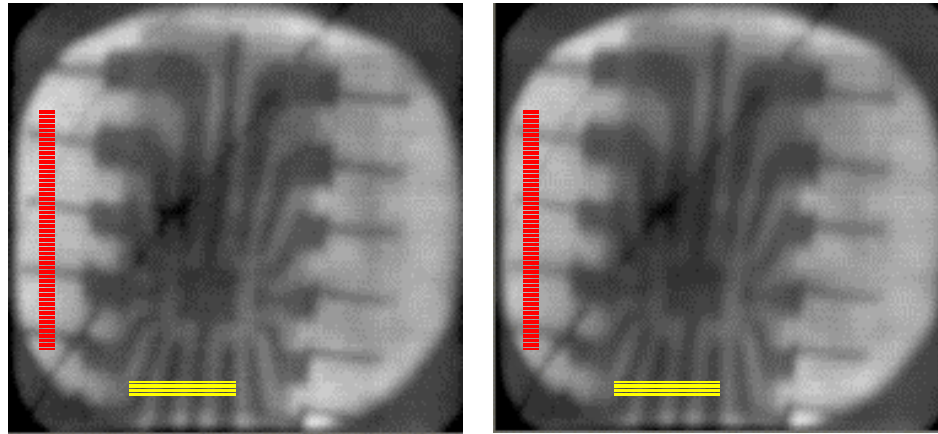

Some wishes of researchers that are driving the technical evolution of delayline detectors very fast (because it is still a long way to go!):

- **Signal / background ratios of 10^6 ?**
- **Permanent random rates in the 10^7 CPS range ?**
- **Spatial resolution of below $20 \mu\text{m}$?**
- **Time resolution of below 20ps ?**

- **and – of course – all together !**

Meander delayline detectors for 1D / 2D / 3D imaging of electrons, ions, and X-rays

Advantages:

- very high reliability
- better performance
- far faster data acquisition
- lower dead time
- better endurance behavior
- improved linearity

Already more than 30 detectors of the new type delivered to be used in:
Germany, France, Austria,
Sweden, Switzerland,
USA, Singapore,
Korea, Taiwan, Japan

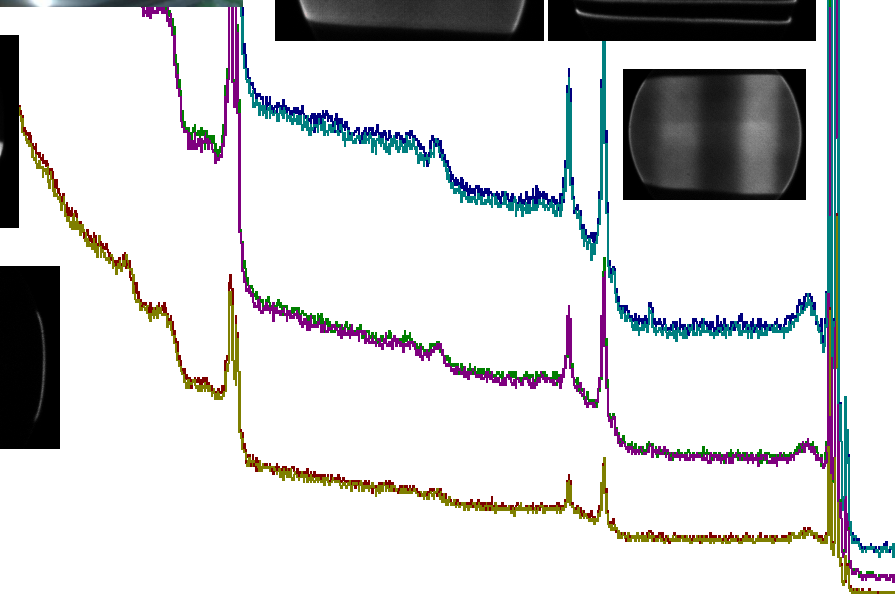
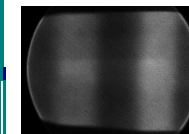
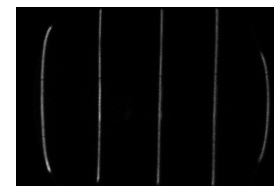
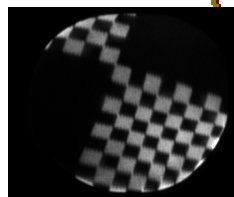
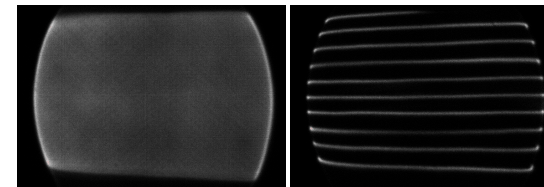
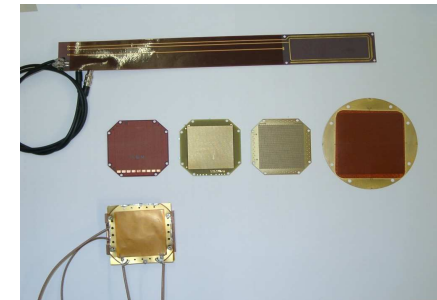

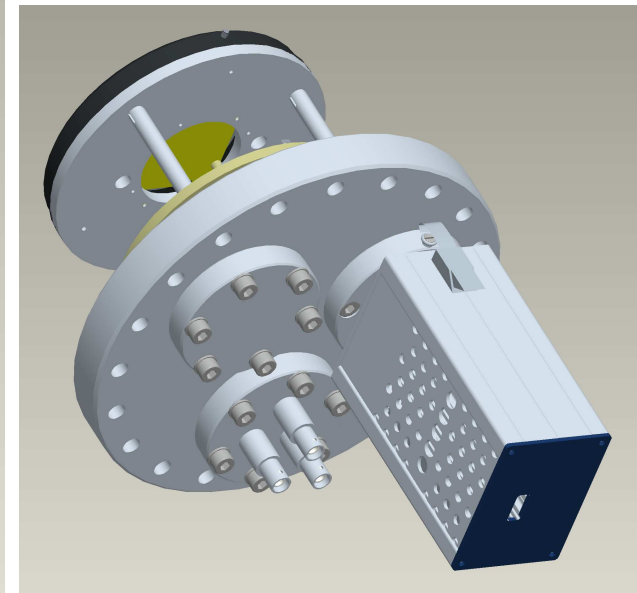
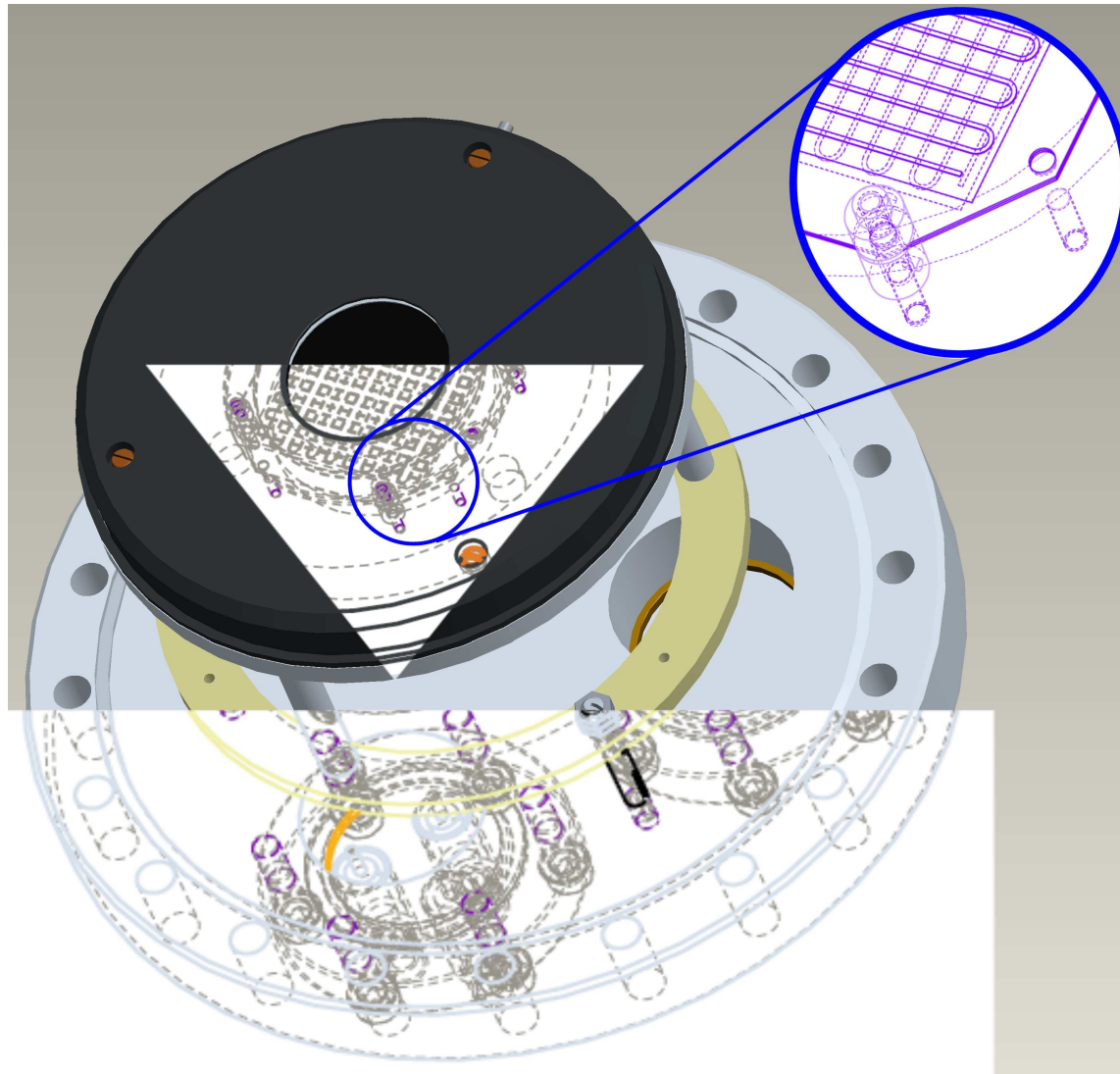

Surface Concept is an expert in custom designed delayline detectors. We build all parts of delayline detectors (active areas, housings, mounting flanges) adapted to the customer's application.

Some of our custom designed detectors out of the last 4 years

- DLD 120120
 - active area: 120x120mm²
- special sized DLD 1818
 - active area: Ø18mm
 - CF40 mounting flange
 - also with interchangeable system
- DLD4242H9
 - hybrid design of a DLD and a 9-segment-detector
 - active area: 42x42mm²
- High Voltage (HV)DLDs
 - base potential of up to -15kV
- HV DLD/ MircoMott Detector Combination
 - HV DLD combined with a micromott detector
 - base potential up to -15kV
- DLD3030-4quad
 - 4-Quadrant Delayline Detector for multiple hit detection
 - active area: 60mm x 60mm
- Encapsulated X-Ray DLDs and EUV DLDs

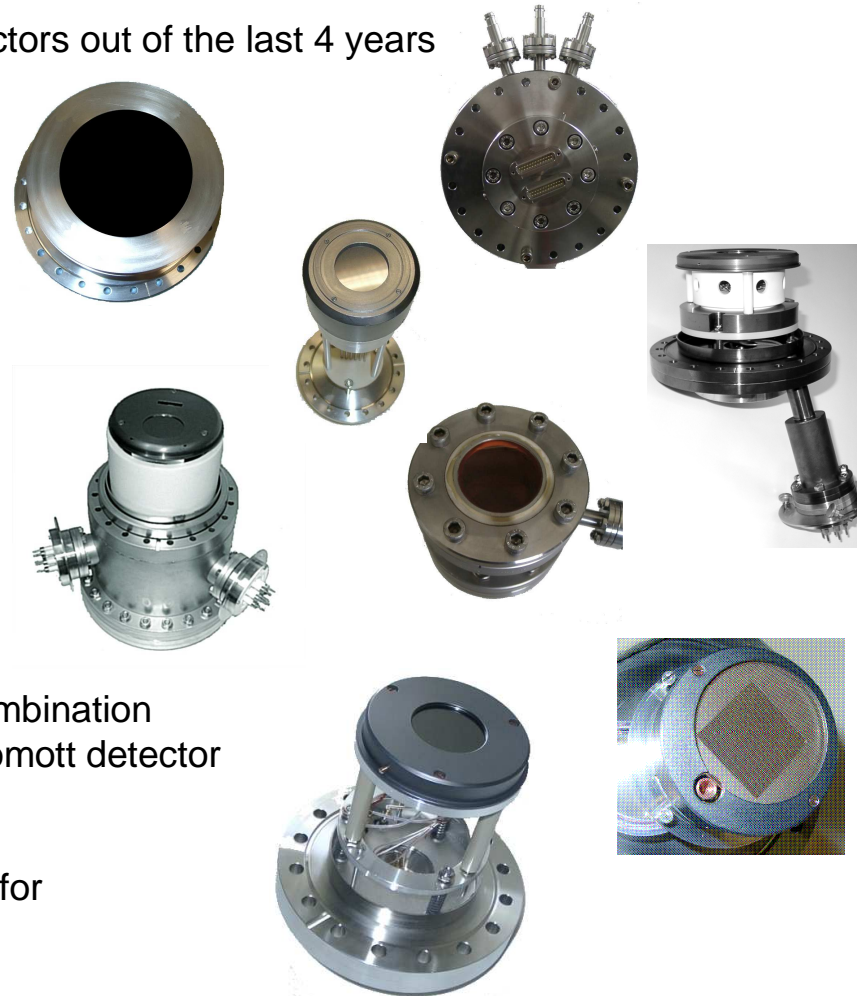

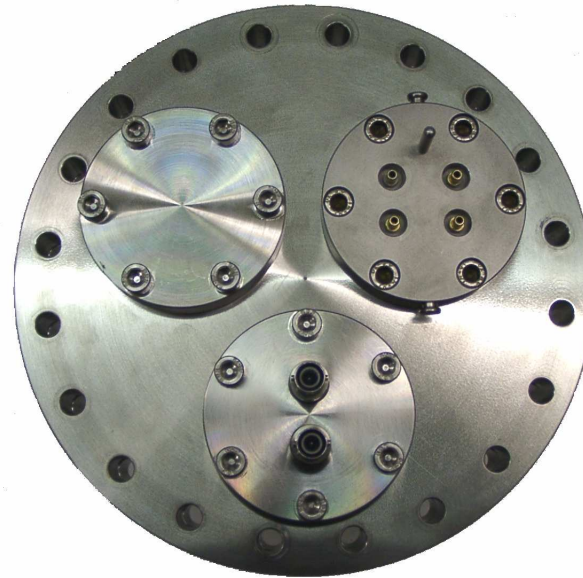
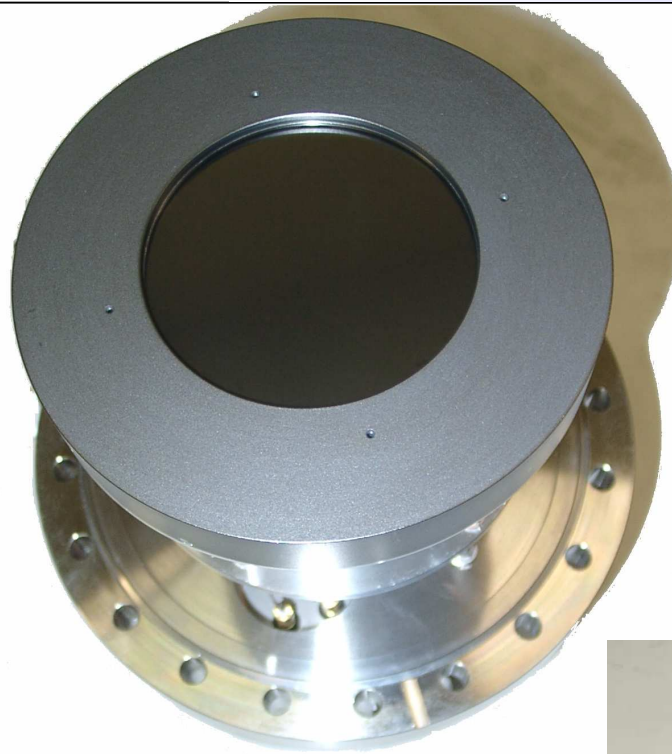



delay line detectors – ultra fast electronics –
picosecond range

Today's delayline detectors can permanently operate above 3 MCPS.
Most of our devices show limits even between 5-8 MCPS.
The record in our lab tests could be seen at about 10.5 MCPS.

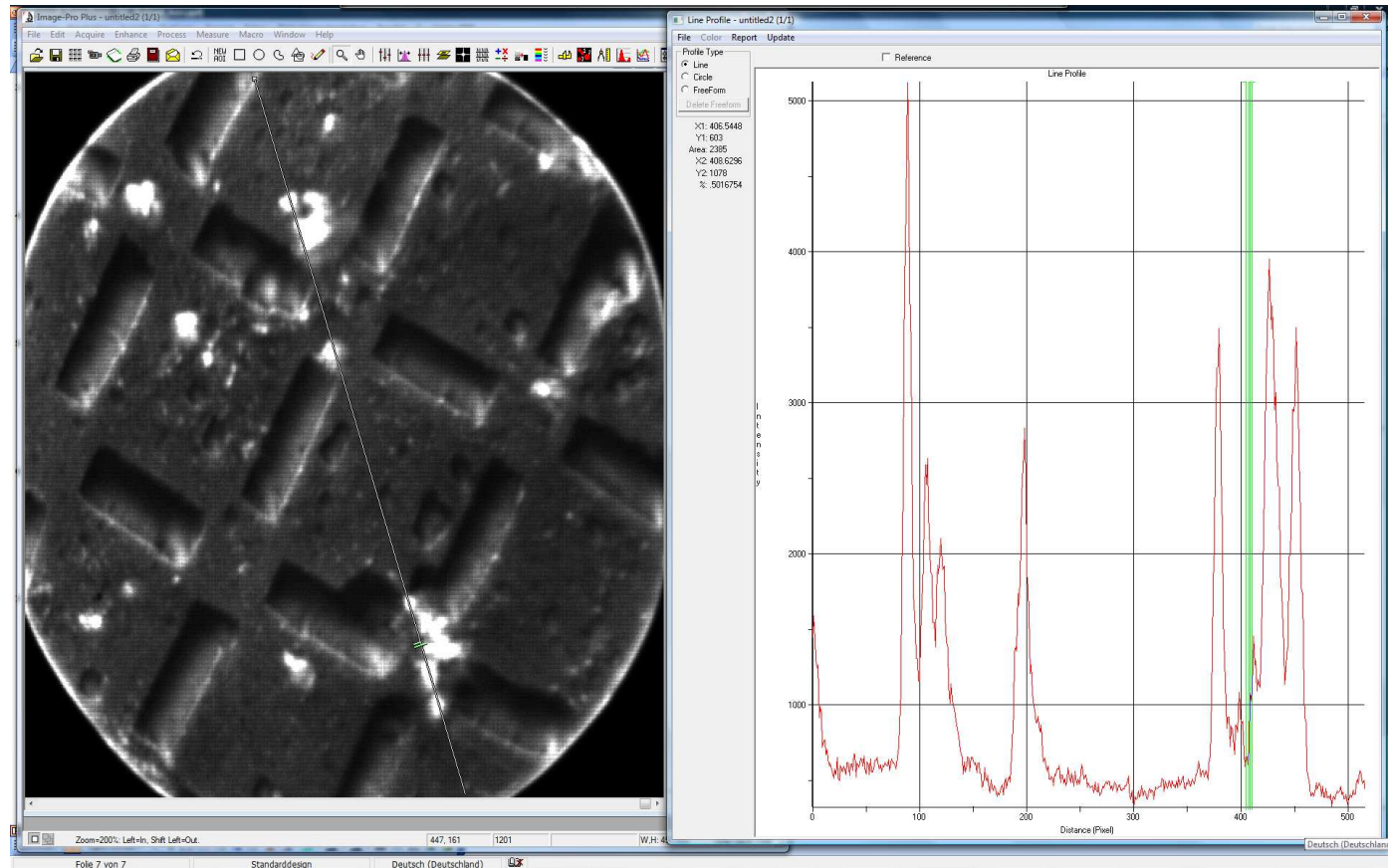
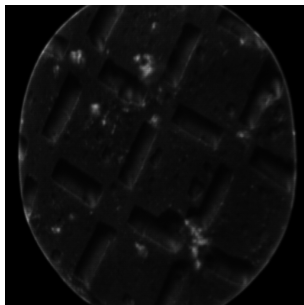
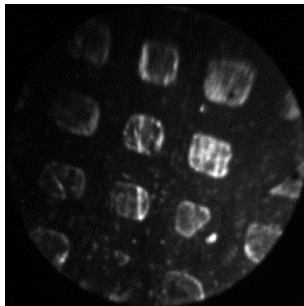
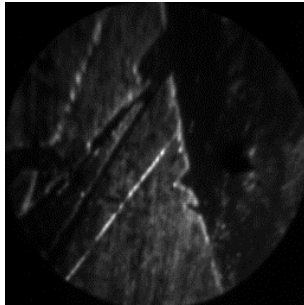

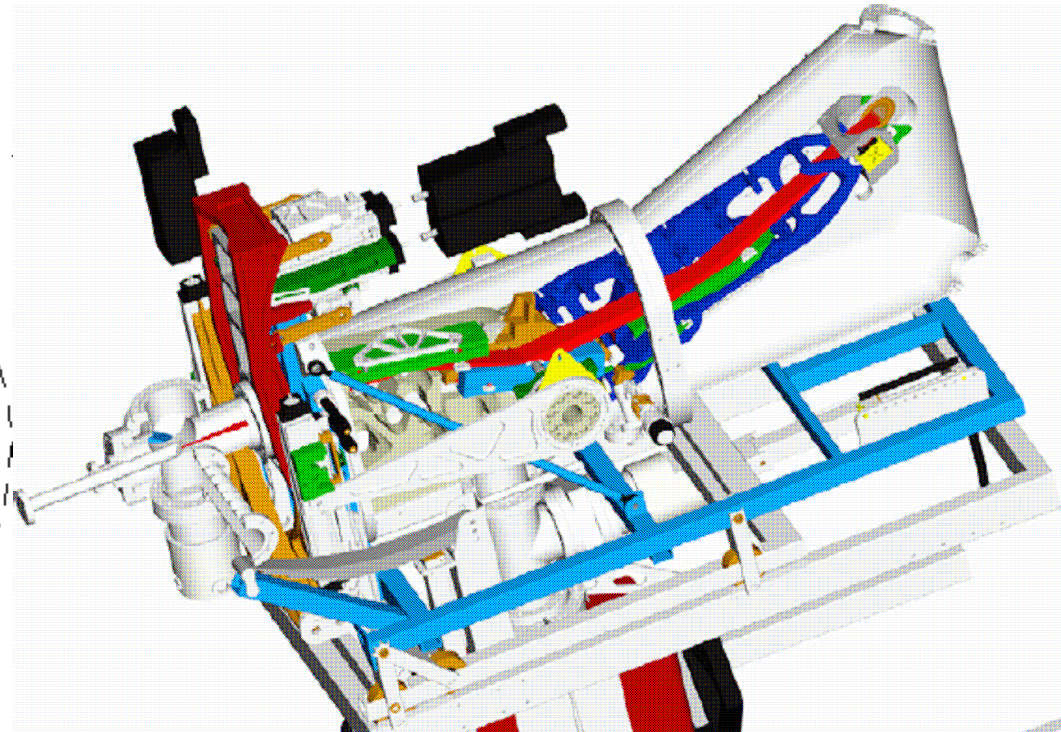
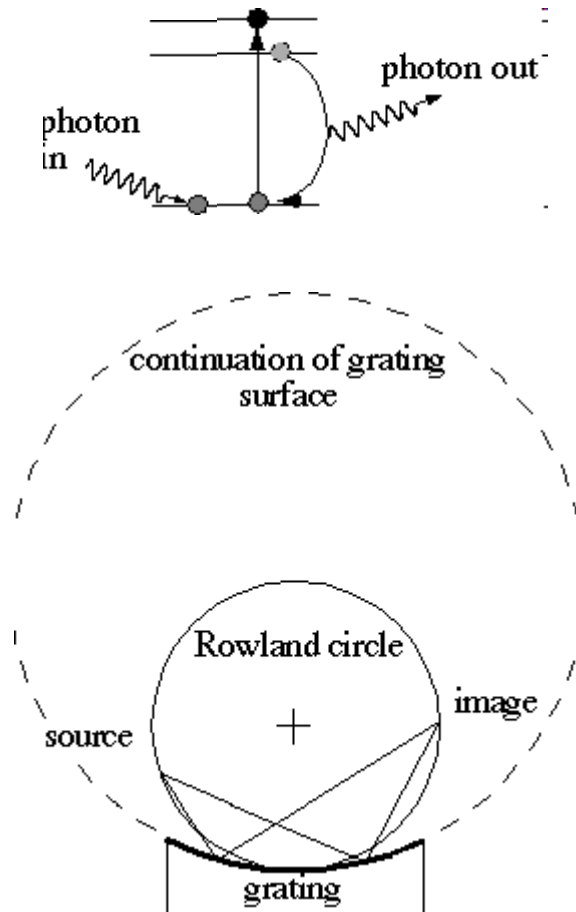

M. Agaker et al., Nucl. Instr. and Meth. in Physics Research A 601 (2009) 213–219

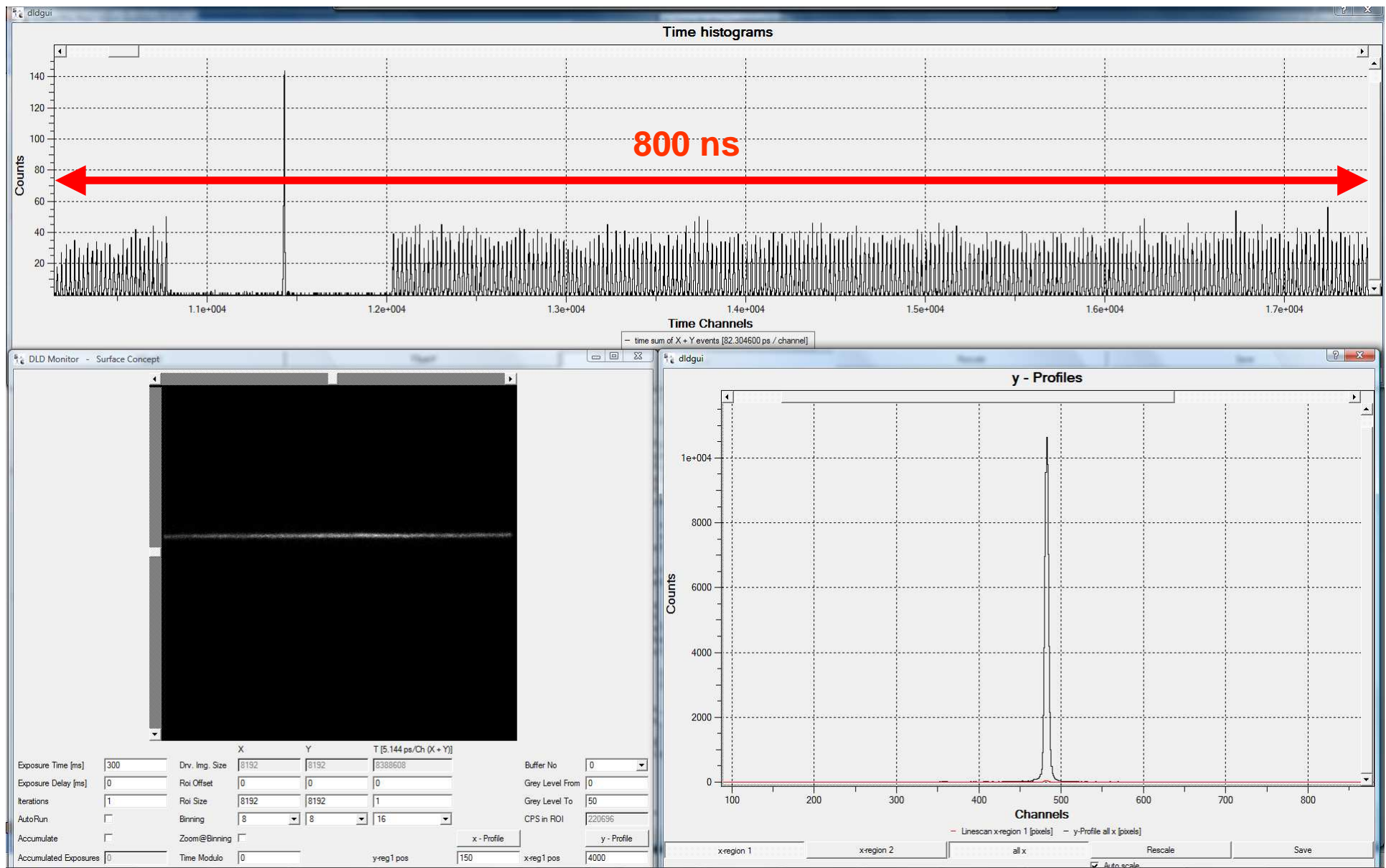

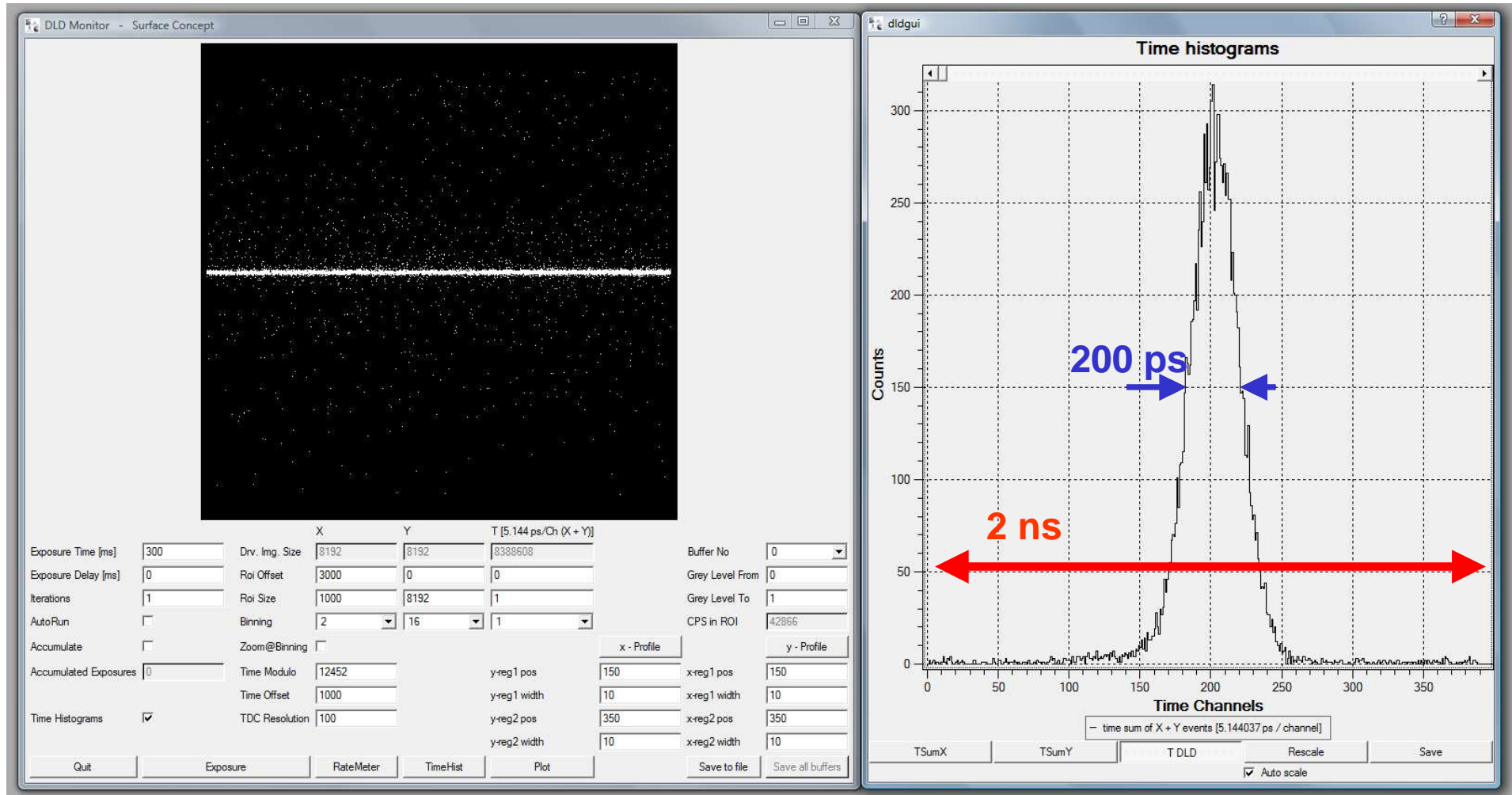

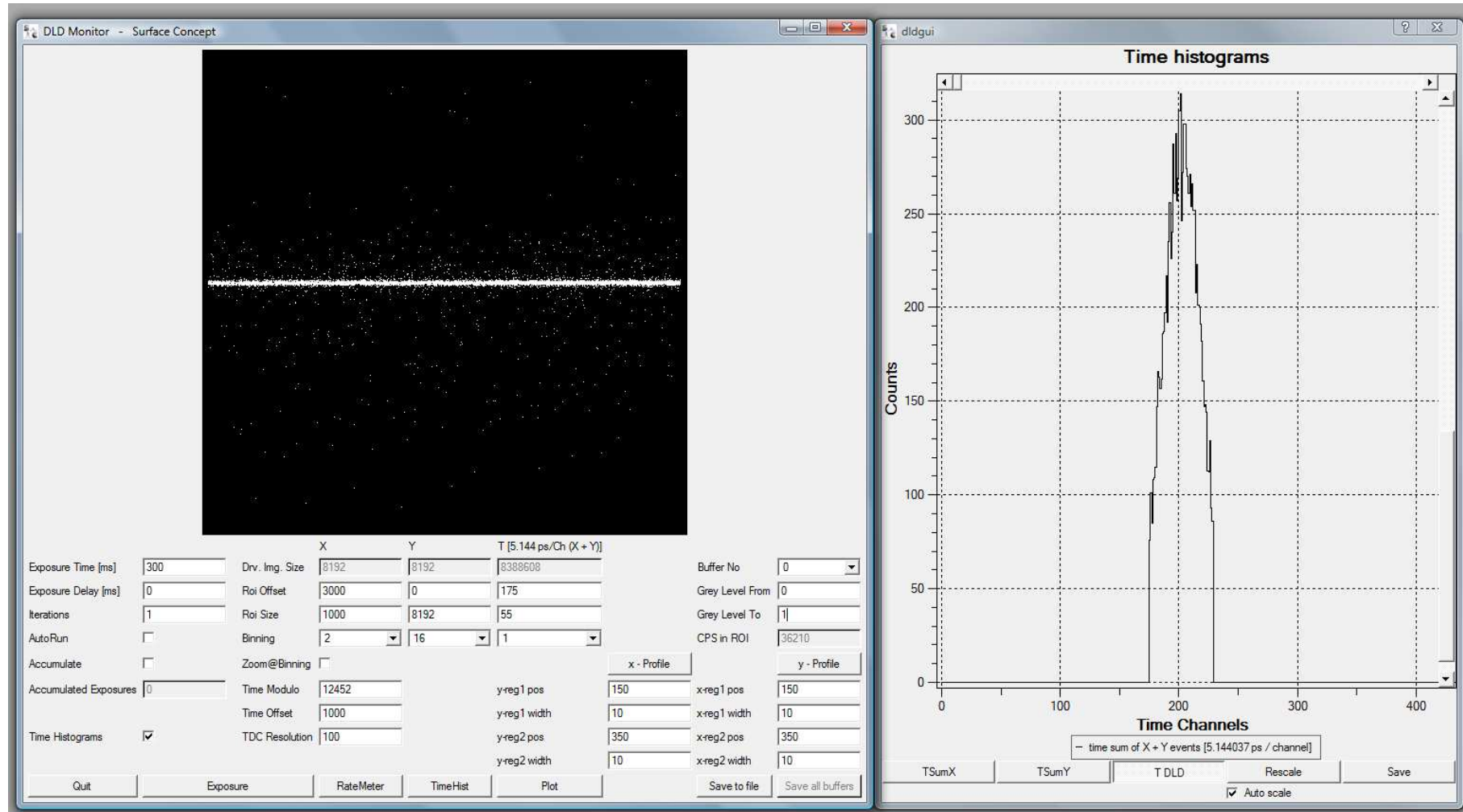

Exposure time: 40 min

Counts outside gate window: 8558 (time period duration 12500 ps)

Counts inside gate window: 1789 (time gate window: 492 ps)

Line scans

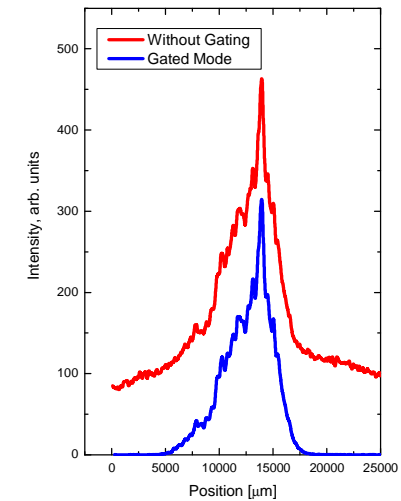

Time distribution of events

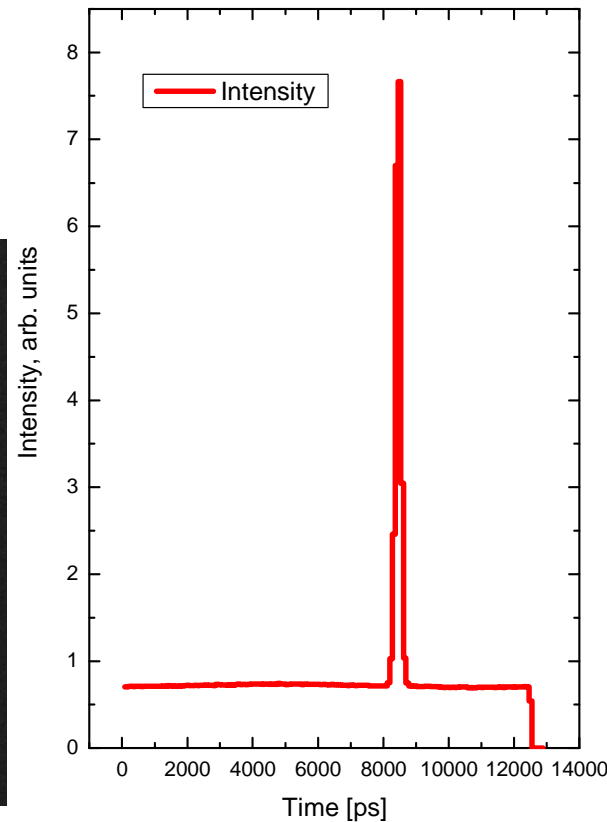

Image taken without time gating

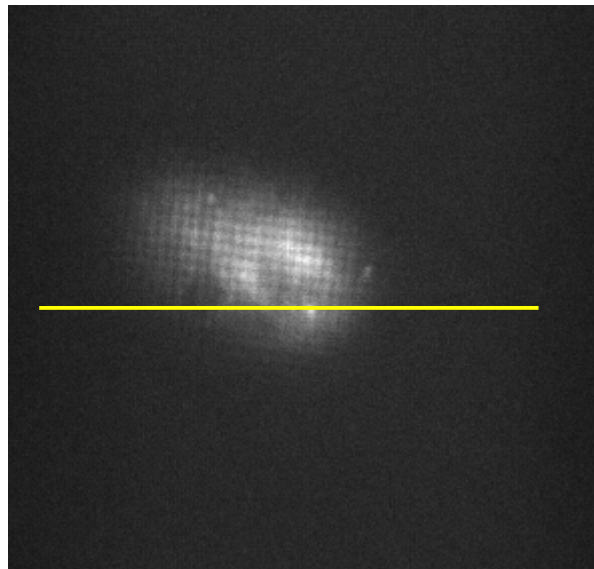
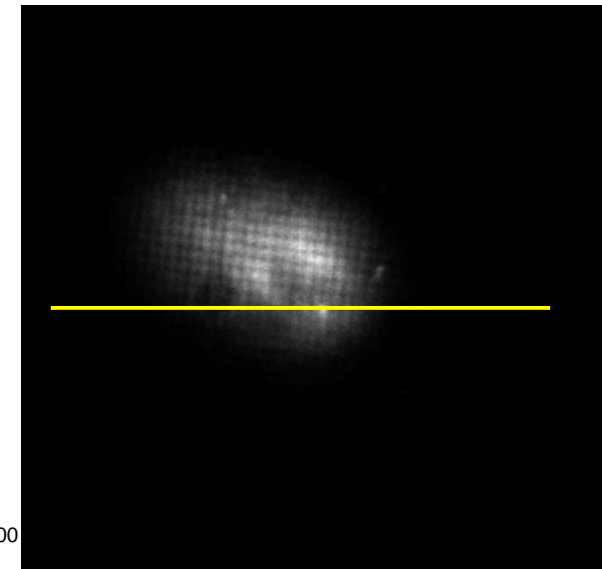
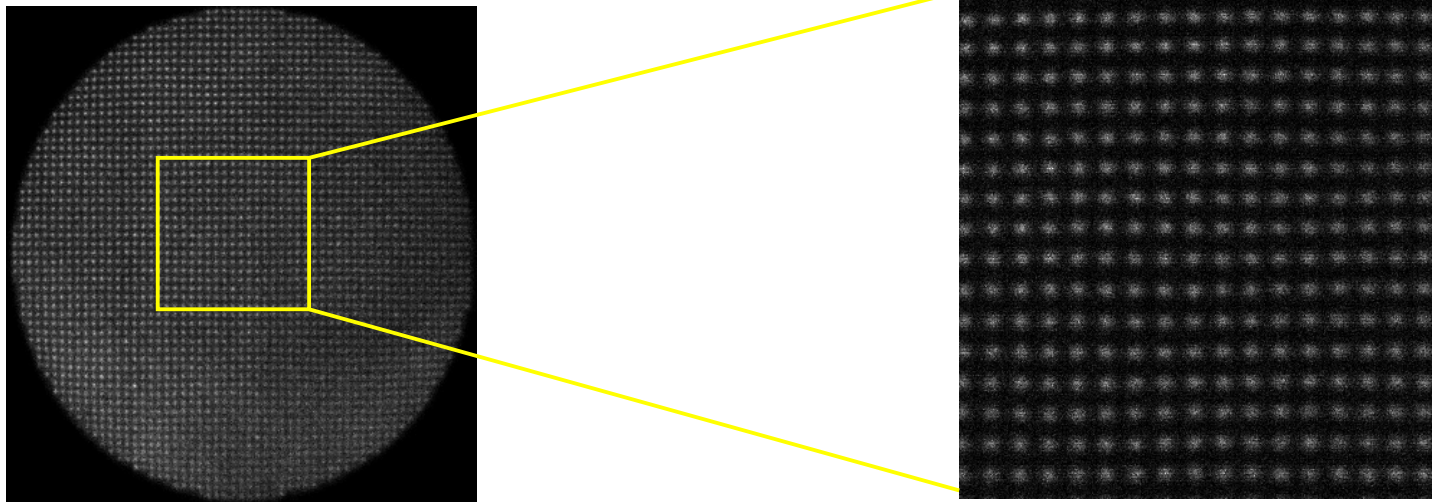

Image taken with time gating



*All wishes together we may have to delay to the very end,
in particular designs, we could achieve the following improvements:*

- **Permanent random rates could improved for all the small DLDs from the 10^5 CPS range to above $3 \cdot 10^6$ CPS**
- **A lab test setup delivered already 10^7 CPS random**
- **Pixel resolution of below $15 \mu\text{m}$ reached for large DLDs**
- **Relative time resolution of 13.7 ps in all DLD systems**



What may single delayline detectors deliver today and where does the journey go to within the near future?

Today:

Time peak FWHM: 150 ps – 250 ps (time slice resolution 13.7 ps)

Spatial resolution: 50 μm – 150 μm (pixel resolutions 12 μm – 48 μm , depending on anode size)

Maximum random count-rates: 3 MCPS – 8 MCPS

Within the next few years:

Time peak FWHM: 50 ps (peak reproducibility 5 ps)

Maximum random count-rates: 20 MCPS – 80 MCPS

Cu (111), electron emission and Shockley surf. states excitation: UV: 4.68 eV (265 nm), IR: 2.10 eV (590 nm)
effective masses $m^*(n=1) \approx 0.4$ and $m^*(n=0) \approx 1.1$

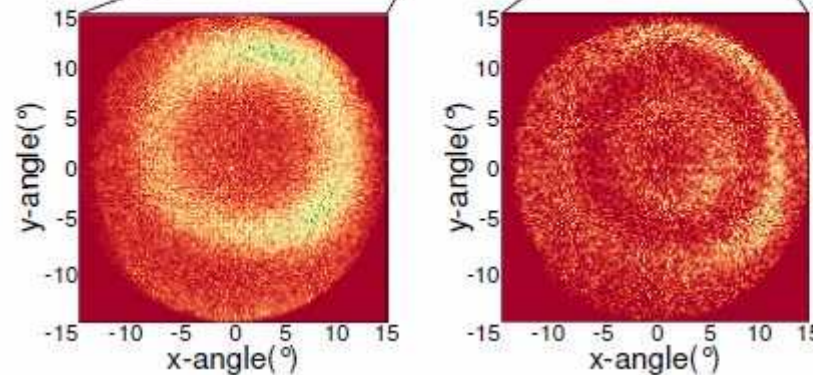
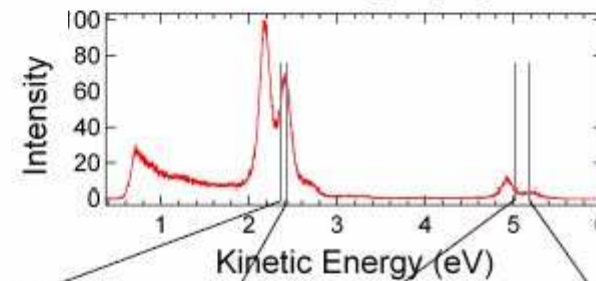
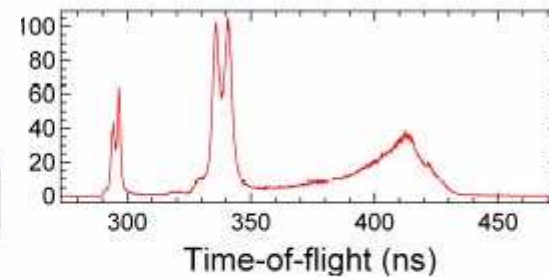
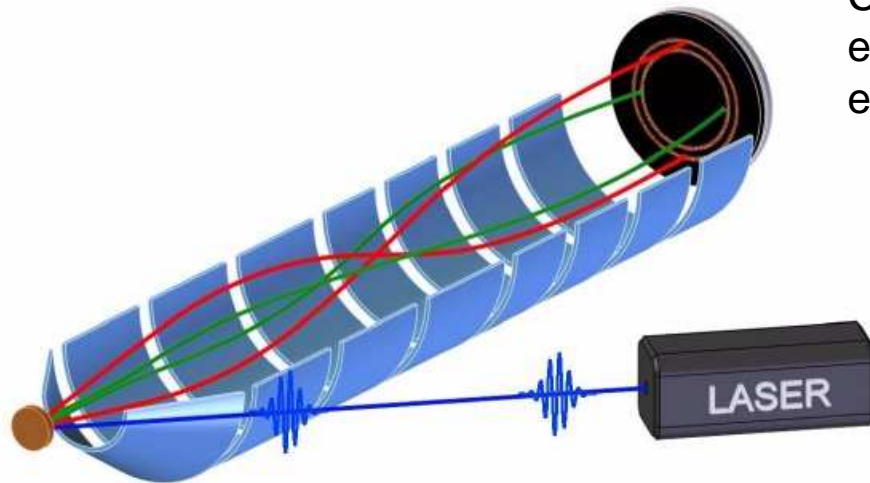

upper panel: Typical time-of-flight spectra recorded at normal emission $\pm 1^\circ$ and deduced energy spectra, measured in normal emission
lower panel: Electron distribution on the detector for the marked energy range (left picture) Shockley surface state (right picture) inner circle : Shockley surface state ($n=0$); outer circle: $n=1$ image-potential state

Jens Kopprasch,
Martin Teichmann,
Martin Weinelt,
Max Born Institute,
Berlin

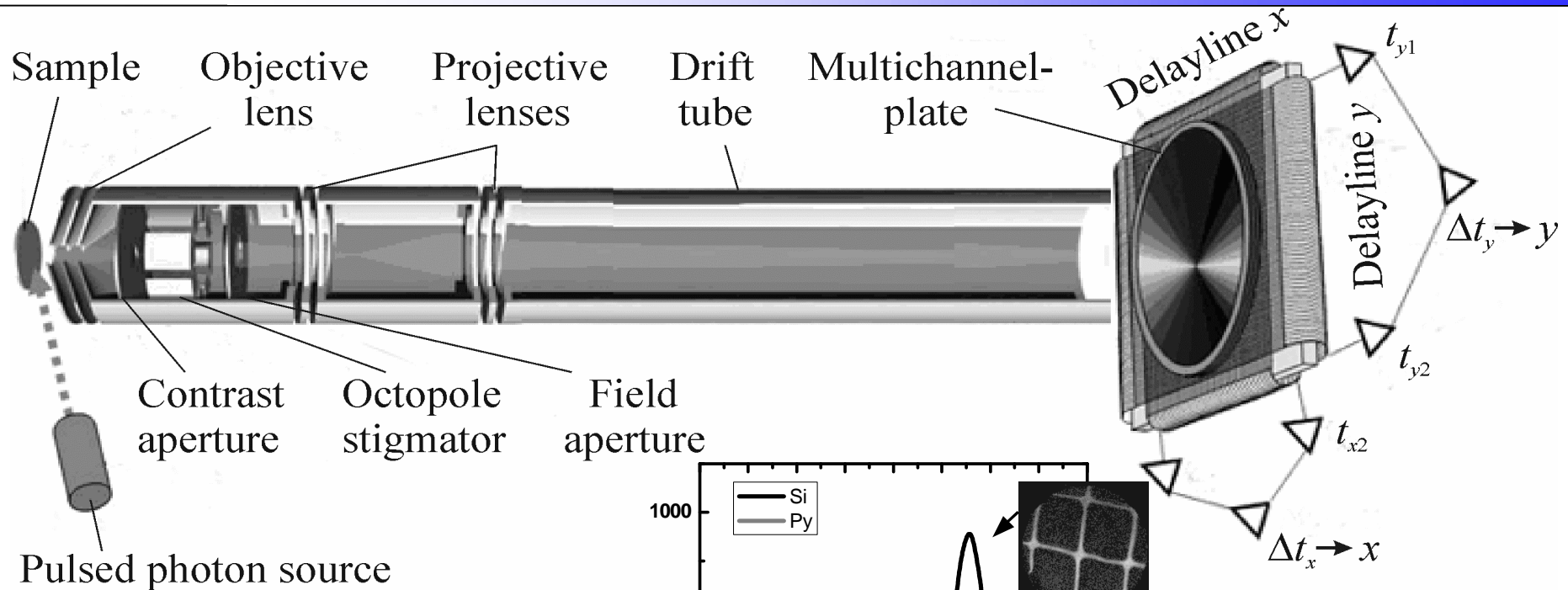

Pulsed photon source

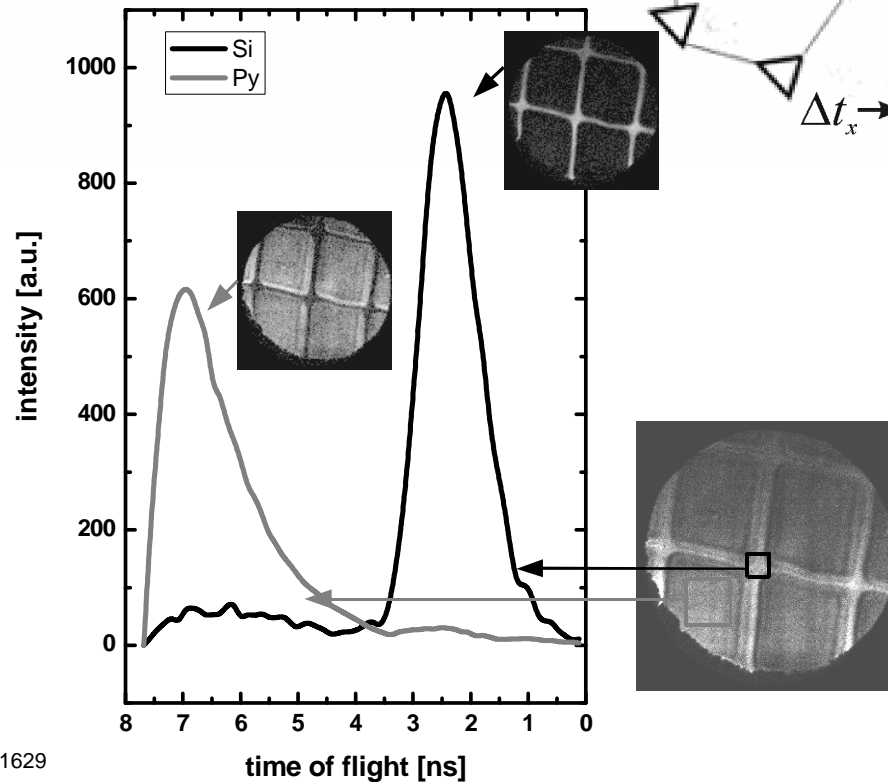
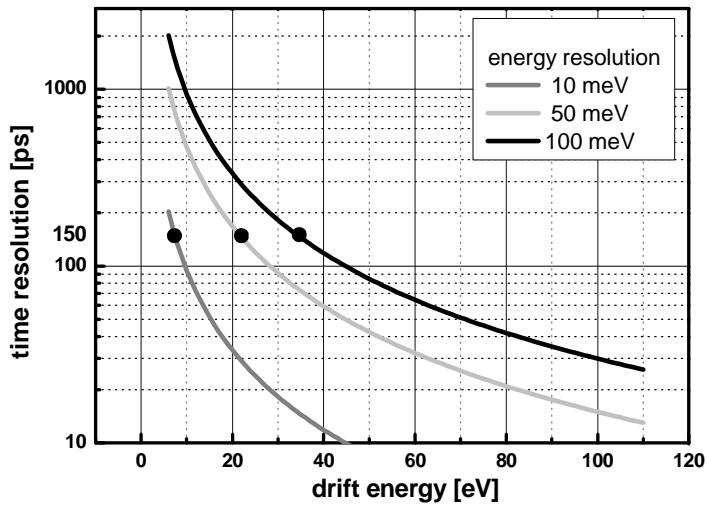

MEFISTO Calibration Facility

MEsskammer für FlugzeitInStrumente und Time-Of-Flight
Calibration Facility for Solar Wind Instrumentation

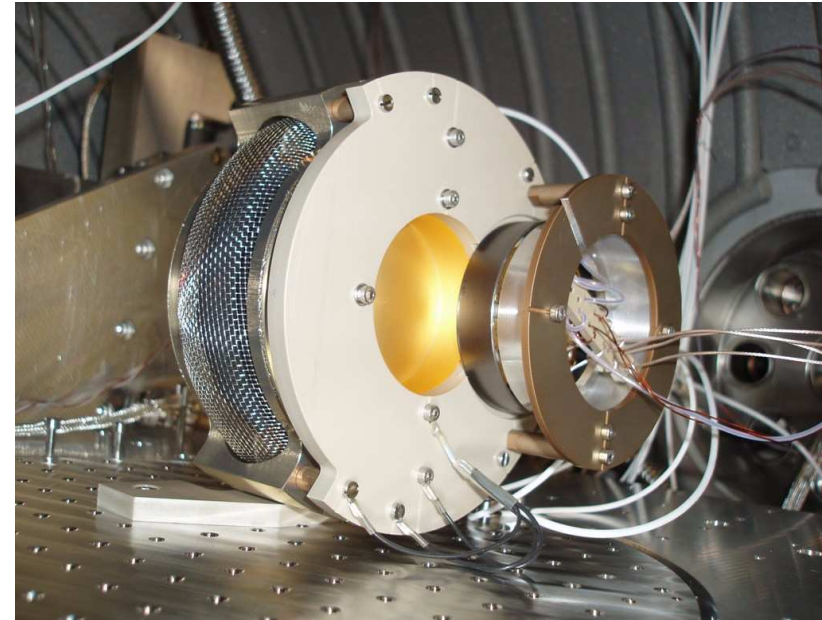

Physics Institute, Space Research and Planetary Sciences
University Bern, Switzerland

- Increases in analyzer performance
- Enables higher resolving power
- Facilitates time resolved experiments
- Snapshot capability for fast spectrum acquisition
- Lower costs for multiplier replacements

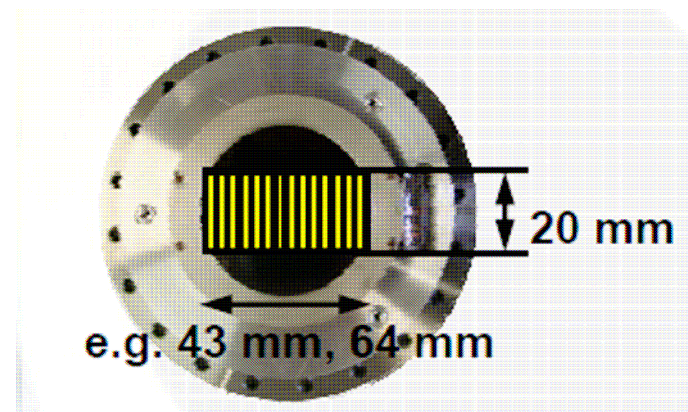

Detector comparison of peak rates in high resolution XPS (Ag 3d_{5/2}):

Resolution	MCD-9	1D Delayline
0.85 eV	1,200,000	1,600,000
0.60 eV	600,000	1000,000
0.50 eV	150,000	250,000

There are different reference period time ranges T_r available which operate with different time resolutions and digital dynamics:

Range	Specification
High precision range	$T_r = 1 \text{ ns} - 40 \text{ } \mu\text{s}$ 2 - 16 time intervals freely definable Resolution 27 ps Using 21 bits dynamics in time measurement results
Extended high precision range	$T_r = 1 \text{ ns} - 950 \text{ s}$ 2 - 16 time intervals freely definable Resolution: 27 ps – 232 ms Time results will be binned together in multiples of two by a user parameter in order to reach longer ranges of T_r using 12 bits dynamics in the time measurement results
Low precision range	$T_r = 1 \text{ } \mu\text{s} - 100 \text{ s}$ 2 - 16 intervals freely definable Resolution: 25 ns Using 32 bits dynamics in time measurement results

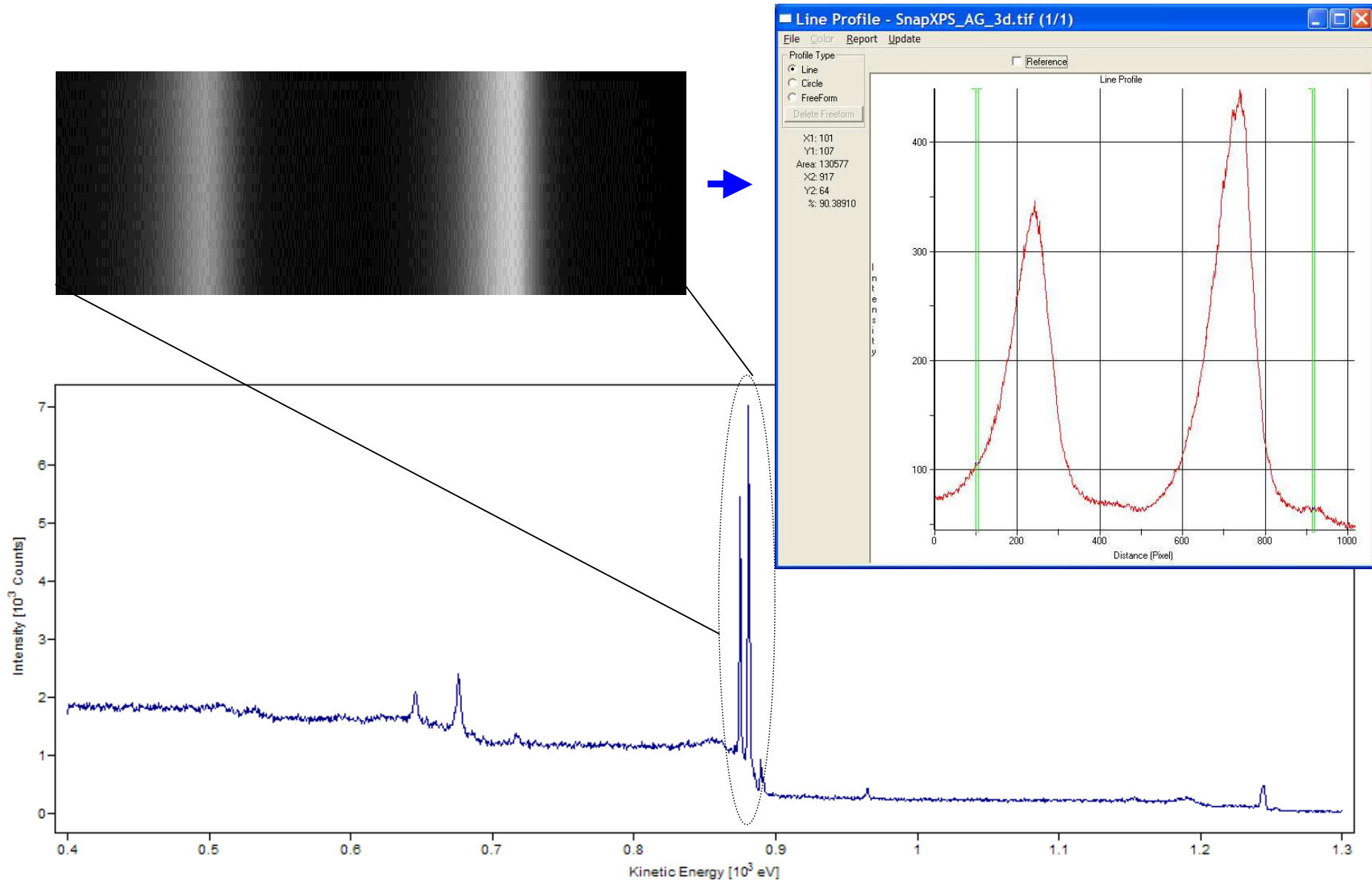

I am very grateful for their excellent contribution on subjects I presented here:

Pasqual Bernhard, Surface Concept GmbH
Dmitri Valdaitsev, Surface Concept GmbH

Ulf Hinze, Boris Chichkov, Laserzentrum Hannover

Markus Agaker, Conny Sathe, University Uppsala, Sweden
(group of Joseph Nordgren)

4 Quadrant multi-hit delayline detector for fast burst imaging

- Multi-hit 4 fold detector optimized for fast burst recognition above 100 MCPS equiv.
- Large detection area 60 mm x 60 mm (60 mm x 30 mm usable in POIBOS 225)
- Real parallel detection of 4 hits without any dead time due to the fourfold design
- Multi hits on single quadrants (all 10 ns possible) are always unambiguous, no data redundancy problems due to the short single delays of about 9 ns.

Features

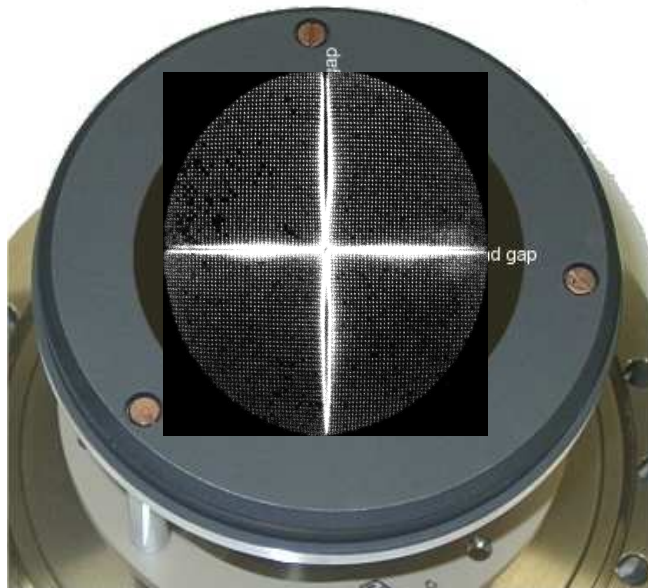

- Multi-hit 2D/3D 4-fold delayline detector
- Up to 4 multi hits with zero dead time
- Up to 400 multi hits per 1 μ s
- Burst rates above 100 MCPS equivalent
- 60 x 60 mm² active area of DLD body and \varnothing 82 mm active MCP area
- Down to 50 μ m of pixel size
- < 250 ps over all time resolution
- Linear response due to single event counting
- Extremely low dark count rate: \leq 10 cps
- Up to 10.5 MCPS cont. count rate in 2D/3D mode

Generation of many partial images → „time - slices“ →

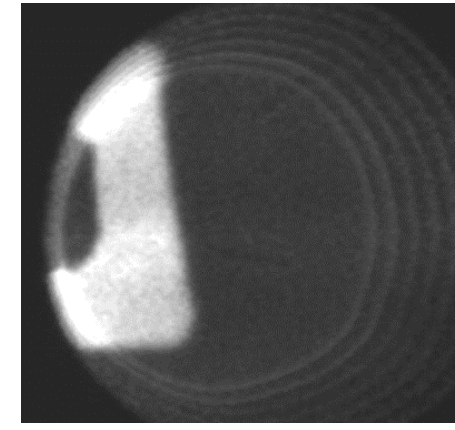
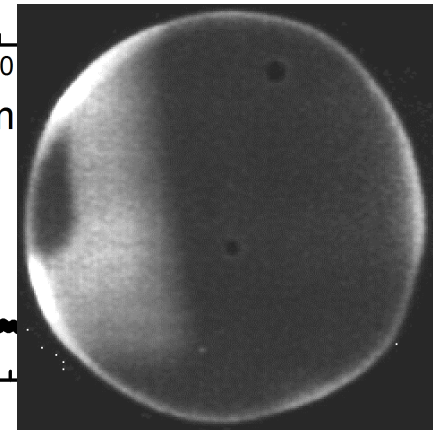
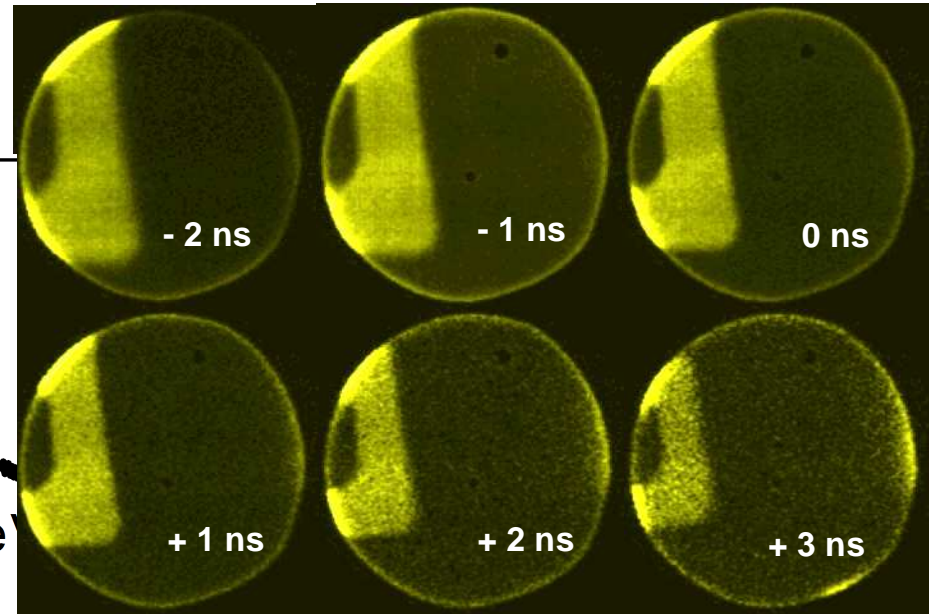
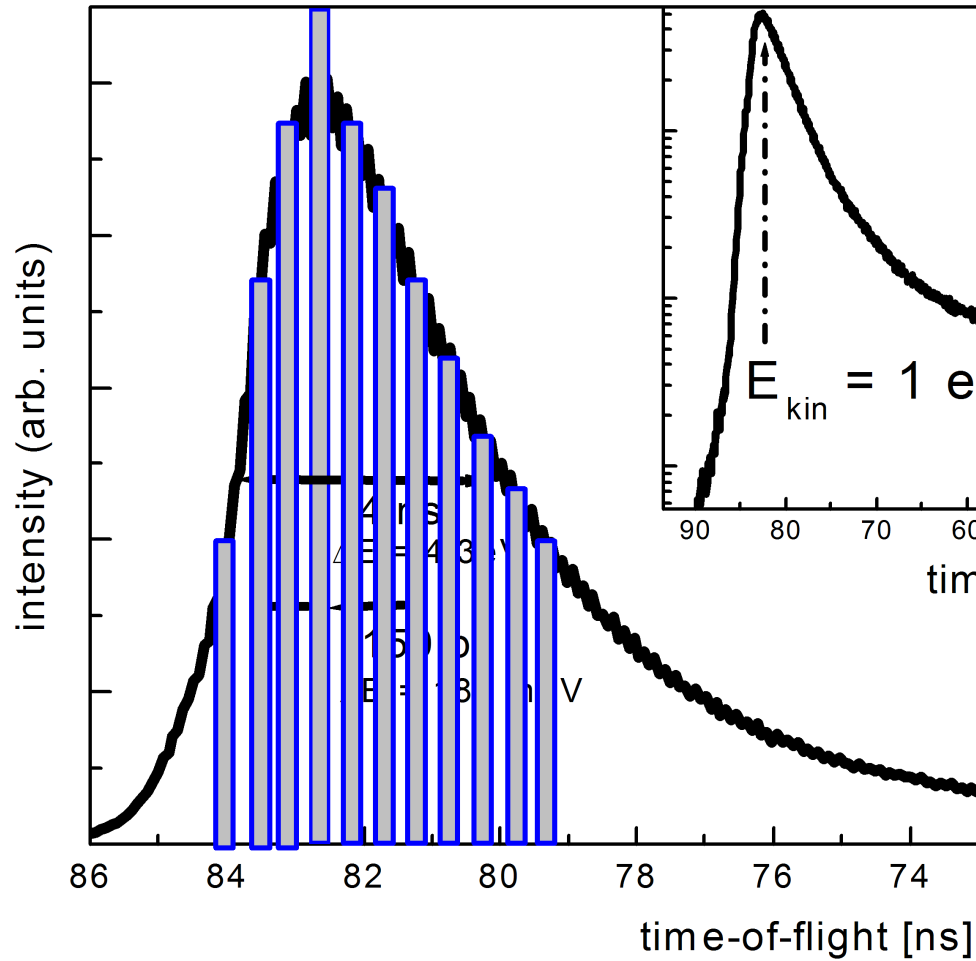

without correction

with correction
i.e. lateral rescaling

Time-of-flight spectromicroscopy → chromatic selector

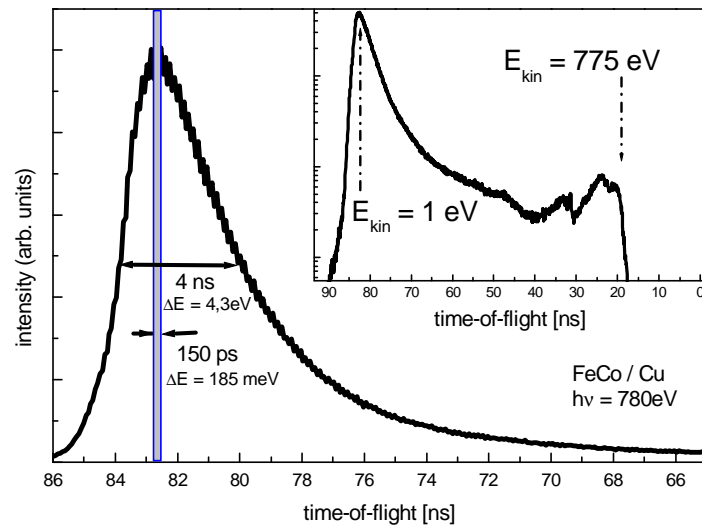

TOF –filtered image

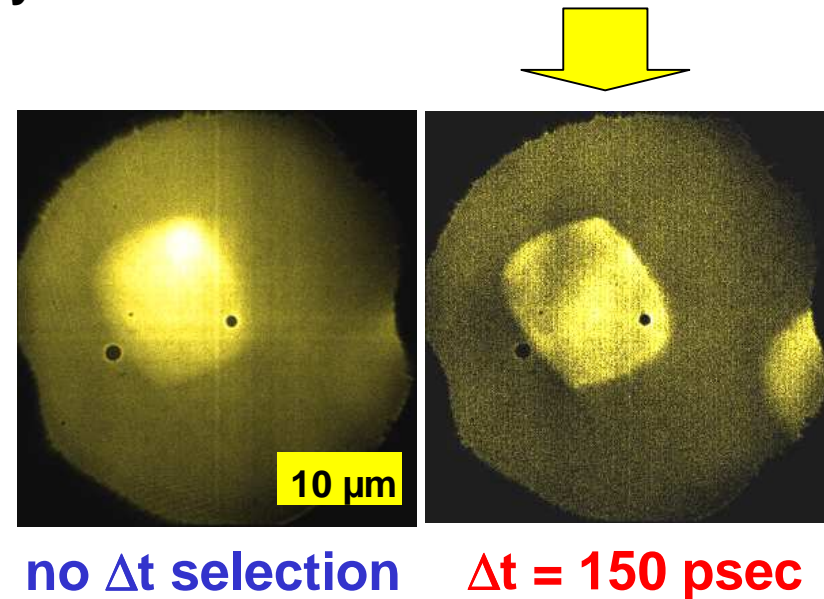

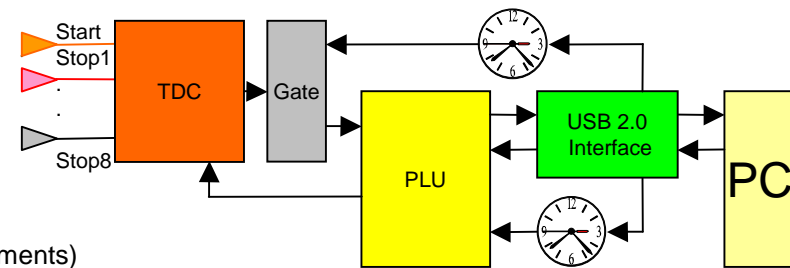
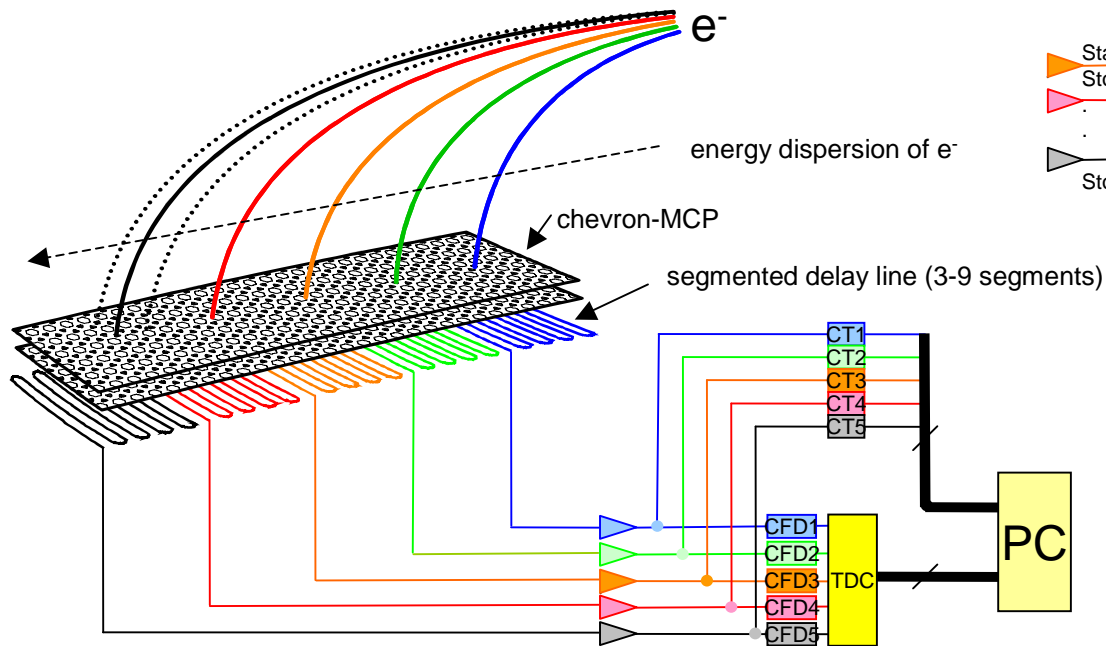
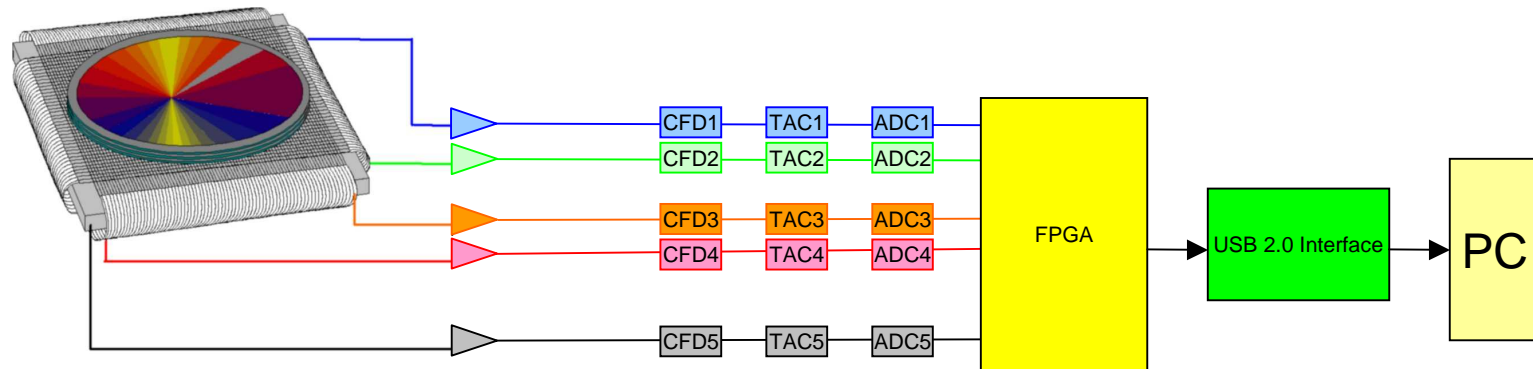

delayline detector –
readout concepts